

SEG and SEG AUTOADAPT

0.9-4.0 kW

50 Hz



be
think
innovate

GRUNDFOS 

1. Introduction	3	13. Grundfos Product Center	60
Introduction	3		
Applications	3		
Construction features	3		
2. Identification	4		
Type key	4		
Nameplate	5		
3. Selection of product	6		
Ordering a pump	6		
Selection of AUTOADAPT applications	7		
4. Performance range	9		
Performance overview	9		
5. Product range	10		
Standard pumps	10		
6. Variants	13		
List of variants	13		
7. Construction	15		
Material specification, SEG pumps	15		
Material specification, SEG AUTOADAPT pumps	20		
8. Product description	26		
Features	26		
Operating conditions	27		
Motor range	28		
Frequency converter operation	28		
Approvals	29		
Wiring diagrams	30		
9. Curve charts	31		
How to read the performance curves	31		
Curve conditions	32		
Performance tests	32		
Certificates	32		
Witness test	32		
10. Performance curves and technical data	33		
SEG.40	33		
SEG.50	42		
11. Dimensions and weights	45		
SEG	45		
SEG AUTOADAPT	49		
12. Accessories	53		
Installation accessories for SEG and SEG AUTOADAPT pumps	53		
Other accessories	53		
SEG pumps	56		
SEG AUTOADAPT pumps	58		

1. Introduction

1.1 Introduction

This data booklet describes Grundfos SEG and SEG AUTO_{ADAPT} sewage pumps.



TM066105



TM066106

SEG and SEG AUTO_{ADAPT} pumps

The SEG pumps are designed with a grinder system which grinds solids into small pieces so that they can be led away through outlet pipes of a relatively small diameter.

The pumps are made of wear-resistant materials, such as cast iron and stainless steel. These materials ensure reliable operation.

The pumps are available with motors of 0.9 kW and up to and including 4.0 kW.

The nominal diameter of the pump outlet port is DN 40 or DN 50.

The pumps are available for two types of installation:

- submerged installation on auto-coupling systems
- submerged installation, free-standing.

1.2 Applications

The SEG and SEG AUTO_{ADAPT} pumps are ideal for use in sparsely populated areas where gravity sewage systems are not available. Examples include small villages, farm areas, and areas with difficult topography, such as rocky terrains with large differences in levels, or any other area where a pressurised system offers advantages.

1.3 Construction features

All pumps have the following features:

- cable connection to motor via stainless-steel cable plug
- corrosion-resistant cable entry filled with watertight polyurethane potting compound
- clamp connection between motor and pump
- cartridge shaft seal
- heavy-duty bearings greased for life
- patented grinder system ensuring extremely high efficiency and reliable operation
- patented SmartTrim system enabling quick and easy impeller clearance adjustment in order to maintain peak performance
- thermal switches built into the motor windings providing protection against overheating
- explosion-proof motors for potentially explosive environments.

Additional AUTO_{ADAPT} features

The AUTO_{ADAPT} pumps incorporate a controller, sensors and motor protection. All you need to do is connect the pump to the mains supply.

The pumps offer the following benefits:

- Built-in level and dry-running sensors.
- Built-in motor protection.
- Pump alternation. If several AUTO_{ADAPT} pumps are installed in the same pit, the control logic incorporated in the pump will ensure that the load is distributed evenly among the pumps over time.
- Alarm relay output. The pump incorporates an alarm relay output. NC and NO are available and can be used as required, for example for acoustic or visual alarms.

Alarm	Alarm log	Signal relay
Overvoltage	•	•
Undervoltage	•	•
Overload	•	•
Blocked motor/pump	•	•
Dry running	•	
Motor temperature	•	•
Electronics temperature (Pt1000)	•	•
Thermal switch 1 in motor	•	•

Alarm	Alarm log	Signal relay
Thermal switch 2 in motor	•	•
Phase sequence reversed	•	•
High-level alarm	•	•
Sensor fault	•	•

- The pump does not start unless the phase sequence is correct.
- Self-calibration after each pump cycle
- Antiseizing function. The antiseizing function will start the pump at programmed intervals to prevent the impeller from seizing up. This function will overrule the dry-running sensor of non-Ex versions.
- Random start delay. This function ensures an even mains load when several pumps are started at the same time after an unintentional power cut.
- Automatic phase sequence detection (three-phase).
- Starting torque boost for additional starting torque (single-phase).
- After-run function (foam draining). The after-run function can be used at programmed intervals if there is a risk of a floating layer.

The Grundfos communication interface unit (CIU) enables data communication via open and interoperable networks such as Profibus, DP, Modbus RTU, LONWorks, BACnet MS/TP®, PROFINET IO, Modbus TCP, GSM/GPRS (wireless), or using Grundfos Remote Management (GRM). CIU can be permanently or temporarily connected for changing the default settings, making further settings or reading the alarm log and operating parameters, such as number of starts and operating hours.

2. Identification

2.1 Type key

The type key covers the entire range of Grundfos SEG and SEG AUTO_{ADAPT} sewage grinder pumps. Each SEG pump can be identified by means of the type key.

Example: SEG.40.12.E.Ex.2.1.502

Code	Explanation	Designation
SE	Grundfos sewage pumps	Pump type
G	Grinder system in the pump inlet	Impeller type
40	Nominal diameter of outlet port [mm]	Pump outlet
50	Nominal diameter of the outlet port for high-flow variants [mm]	
12	Code number from type designation / 10 [kW]	Output power
[]	Standard, without equipment	Sensor version
E	Electronic version with AUTO _{ADAPT} functions	
[]	Standard pump	Pump version
Ex	Explosion-proof pump	
2	2-pole	Number of poles
1	Single-phase motor	Number of phases
[]	Three-phase motor	
5	50 Hz	Frequency [Hz]

Code	Explanation	Designation
02	230 V, DOL	Supply voltage and starting method
0B	400-415 V, DOL	
0C	230-240 V, DOL	
[]	First generation	Generation *
A	Second generation	
B	Third generation	
[]	Standard material (EN-GJL-200)	Pump material
Z	Custom-built pump	Customisation

* The pumps belonging to the individual generations differ in design but are similar in terms of power rating.

2.2 Nameplate

The nameplate states the operating data and approvals applying to the pump.

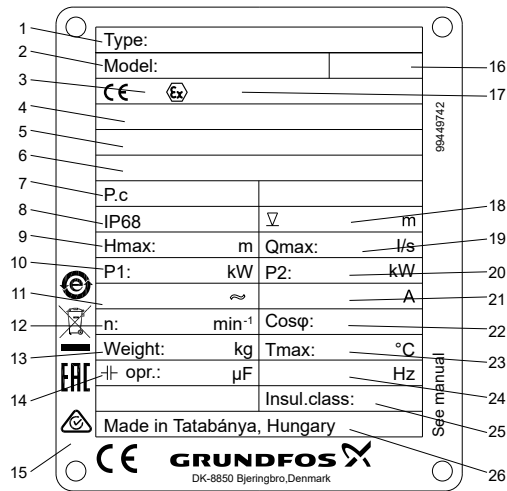

TM058872

SEG and SEG AUTO_{ADAPT} nameplate

Pos.	Description
1	Type designation
2	Product number
3	Approval
4	ATEX certificate number
5	IEC Ex description
6	IEC Ex certificate number
7	Production code, year and week
8	Enclosure class according to IEC 60529
9	Maximum head [m]
10	Rated input power [kW]
11	Rated voltage
12	Speed [rpm]
13	Net weight [kg]
14	EAC mark *
15	Run capacitor [μF]
16	RCM logo **
17	CE mark
18	Installation and operating instructions, publication number
19	Ex description
20	Maximum installation depth [m]
21	Maximum flow rate [l/s]
22	Rated power output [kW]
23	Maximum current [A]
24	Cos φ, 1/1 load
25	Maximum liquid temperature [°C]
26	Frequency [Hz]
27	Insulation class
28	Production country

* For Russia only.

** For Australia only.

3. Selection of product

3.1 Ordering a pump

When ordering a pump, you need to take the following aspects into consideration:

- pump type
- custom-built variation (option)
- accessories
- controller
- explosion-proof version.

Pump type

When you have selected the pump type, you can identify the specific pump that best meets your needs in [5. Product range](#) and Type key on page [Type key](#).

The list below is a detailed description of the product you get if you order the following pump:

Pump	Product number
SEG.40.09.2.1.502	96075893

- Pump as specified in the type key.
- 10 m of cable.
- Paint: NCS 9000 N/RAL 9005 (black), gloss code 30 ± 10 (according to ISO 2813), thickness of minimum 100 µm and maximum 200 µm.
- Thermal switches built into the motor windings.
- Tested according to ISO 9906:2012, grade 3B.

See [10. Performance curves and technical data](#) for selection of a pump.

Note: Pump-specific data can also be found in Grundfos Product Center at www.grundfos.com by entering the product number 96075893. For further information on Grundfos Product Center, see [13. Grundfos Product Center](#).

Custom-built variants

The pumps can be customised to meet individual requirements. Many pump features and options are available for customisation, such as explosion-proof versions, cable lengths or special materials.

Accessories

Depending on installation type and pump variant, accessories may be required. See [12. Accessories](#) for selection of the correct accessories.

Note: Ordered accessories are not fitted from factory.

Controller

The following controllers are available:

SEG

- Dedicated Controls See Dedicated Controls.
- LC and LCD 107 operated by air bells. See LC and LCD.
- LC and LCD 108 operated by float switches. See LC and LCD.
- LC and LCD 110 operated by electrodes. See LC and LCD.

- CU 100. See CU 100.

SEG AUTO_{ADAPT}

- Built-in controller. See [12.4.1 Grundfos CIU](#).
- Grundfos CIU. See [12.4.1 Grundfos CIU](#).
- Grundfos GO. See Grundfos GO Remote.

Explosion-proof version

Both pump ranges are available in explosion-proof versions. See section [Approvals](#).

Related information

[2.1 Type key](#)

[8.5 Approvals](#)

3.2 Selection of AUTO_{ADAPT} applications

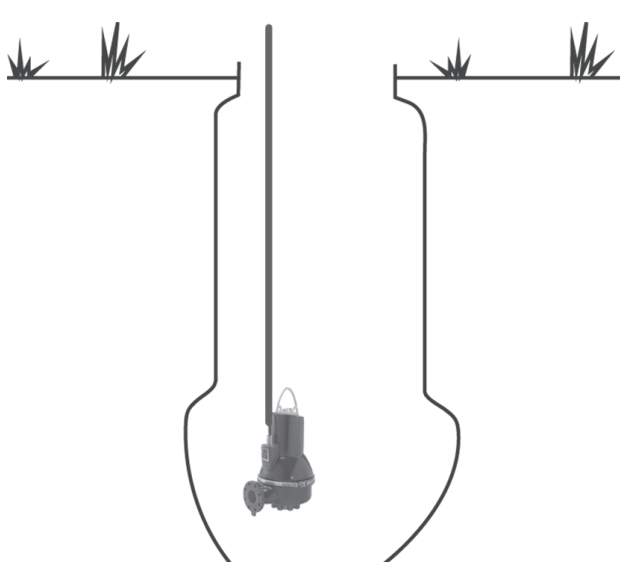
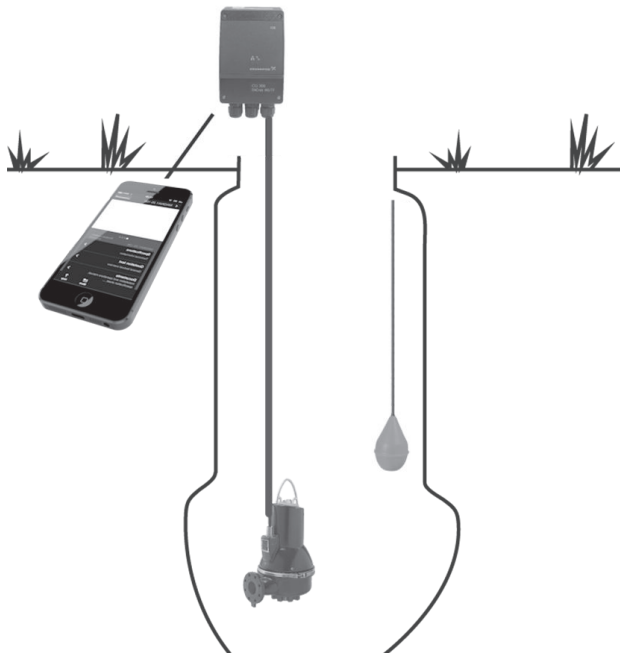
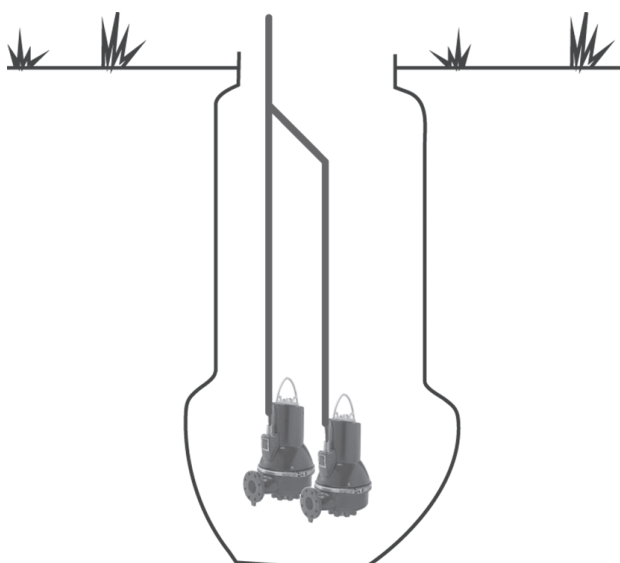
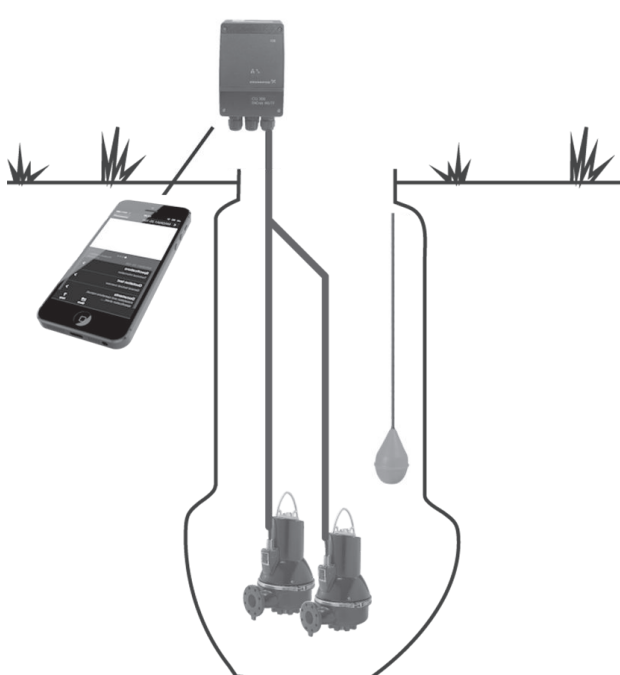
Pump(s) with factory settings	Pump(s) with CIU and level switch - Case 1
 <p style="text-align: right; font-size: small;">TM064350</p>	 <p style="text-align: right; font-size: small;">TM064352</p>
 <p style="text-align: right; font-size: small;">TM064354</p>	 <p style="text-align: right; font-size: small;">TM064356</p>
<p>Configuration for one or two AUTO_{ADAPT} pumps</p> <p>Configuration for one or two AUTO_{ADAPT} pumps with factory settings: alarm relay integrated in pump(s) no need for change in settings or data communication.</p>	<p>Configuration for one or two AUTO_{ADAPT} pumps with CIU and level switch - Case 1</p> <p>Configuration for one or two AUTO_{ADAPT} pumps with one level switch and one CIU for data communication: need for high-level alarm indication only CIU to consider: CIU 902 or CIU 902 + CIM 060.</p> <p>Note: Changes in settings are made by means of infrared or radio communication via Grundfos GO Remote.</p>

Pump(s) with CIU

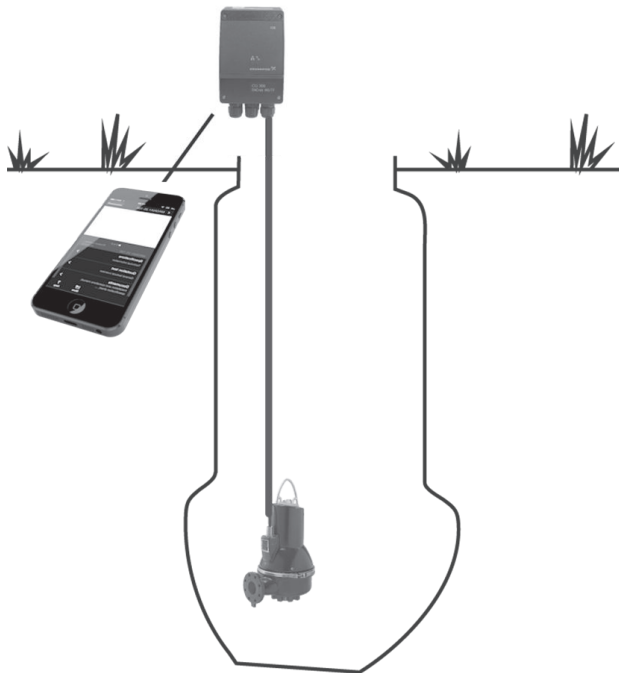

TM064351

Pump(s) with CIU and level switch - Case 2

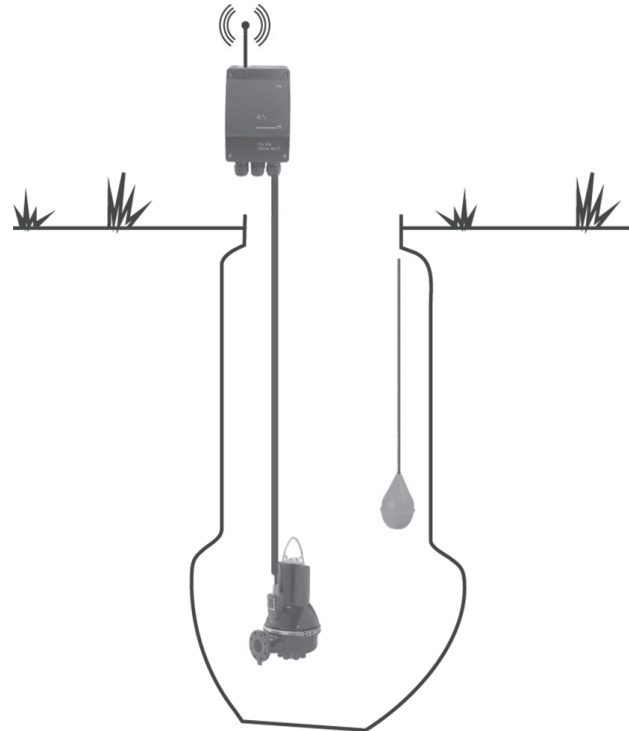

TM064353

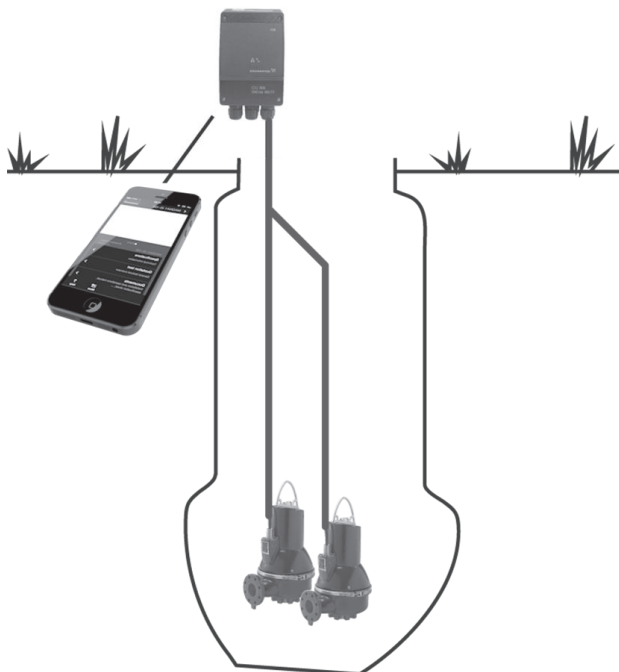

TM064355

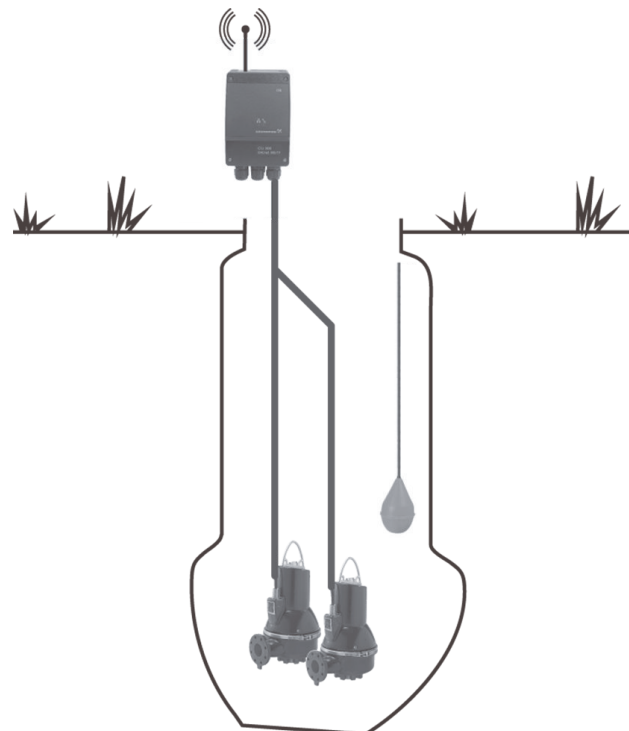

TM064357

Configuration for one or two AUTO_{ADAPT} pumps with CIU

Configuration for one or two AUTO_{ADAPT} pumps with one CIU for data communication:

need for data change in settings

CIU to consider:

CIU 902 or

CIU 902 + CIM 060.

Note: Changes in settings are made by means of infrared or radio communication via Grundfos GO Remote.

Configuration for one or two AUTO_{ADAPT} pumps with CIU and level switch - Case 2

Configuration for one or two AUTO_{ADAPT} pumps with one level switch and one CIU for data communication:

need for high-level alarm indication and/or data communication

CIU to consider:

CIU 202 for wired Modbus RTU

CIU 152 for Profibus DP

CIU 252 for GSM/GPRS

CIU 272 for GRM.

4. Performance range

4.1 Performance overview

Figure 4.1 *Performance overview* shows the performance range of SEG and SEG AUTO_{ADAPT} pumps as well as the explosion-proof versions. It gives an overview of the various sizes.

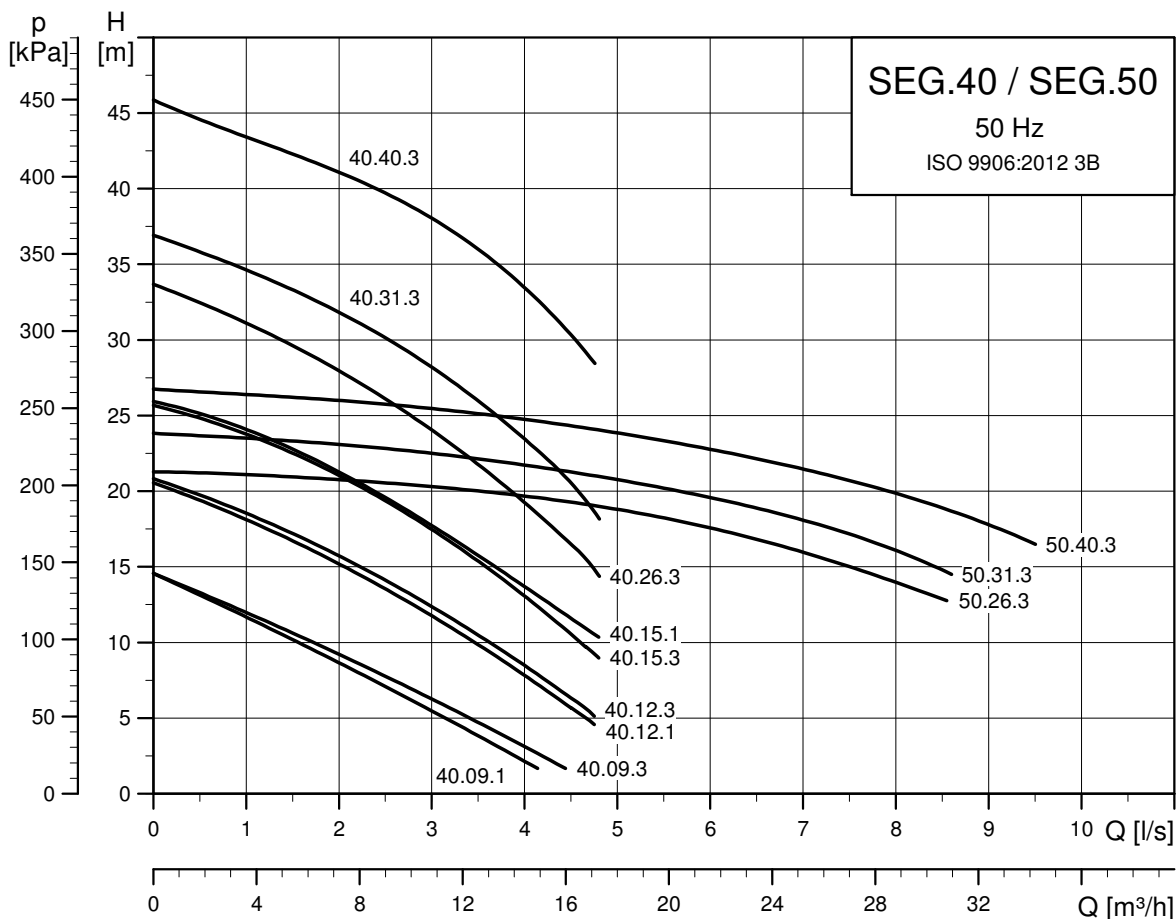

TM025265

Performance range

Pump	Curve number	
SEG.40.09.(E). (Ex).2.1.502	40.09.1	10.1.1 SEG.40.09.(E).(Ex).2.1.502
SEG.40.09.(E). (Ex).2.50B/C	40.09.3	10.1.2 SEG.40.09.(E).(Ex).2.50B/C
SEG.40.12.(E). (Ex).2.1.502	40.12.1	10.1.3 SEG.40.12.(E).(Ex).2.1.502
SEG.40.12.(E). (Ex).2.50B/C	40.12.3	10.1.4 SEG.40.12.(E).(Ex).2.50B/C
SEG.40.15.(E). (Ex).2.1.502	40.15.1	10.1.5 SEG.40.15.(E).(Ex).2.1.502
SEG.40.15.(E). (Ex).2.50B/C	40.15.3	10.1.6 SEG.40.15.(E).(Ex).2.50B/C
SEG.40.26.(E). (Ex).2.50B/C	40.26.3	10.1.7 SEG.40.26.(E).(Ex).2.50B/C
SEG.40.31.(E). (Ex).2.50B/C	40.31.3	10.1.8 SEG.40.31.(E).(Ex).2.50B/C

Pump	Curve number	
SEG.40.40.(E). (Ex).2.50B/C	40.40.3	10.1.9 SEG.40.40.(E).(Ex).2.50B/C
SEG.50.26.(E). (Ex).2.50B/C	50.26.3	10.2.1 SEG.50.26.(E).(Ex).2.50B/C
SEG.50.31.(E). (Ex).2.50B/C	50.31.3	10.2.2 SEG.50.31.(E).(Ex).2.50B/C
SEG.50.40.(E). (Ex).2.50B/C	50.40.3	10.2.3 SEG.50.40.(E).(Ex).2.50B/C

5. Product range

5.1 Standard pumps

5.1.1 SEG standard

Pump type	Supply voltage [V]	Starting method	Cable length [m]	Thermal protection	Product number
SEG.40.09.2.1.502	1 x 230	DOL	10	Thermal switch	96075893
SEG.40.09.2.50B	3 x 400-415	DOL	10	Thermal switch	96075897
SEG.40.12.2.1.502	1 x 230	DOL	10	Thermal switch	96075901
SEG.40.12.2.50B	3 x 400-415	DOL	10	Thermal switch	96075905
SEG.40.15.2.1.502	1 x 230	DOL	10	Thermal switch	98280724
SEG.40.15.2.50B	3 x 400-415	DOL	10	Thermal switch	96075909
SEG.40.26.2.50B	3 x 400-415	DOL	10	Thermal switch	96075913
SEG.40.31.2.50B	3 x 400-415	DOL	10	Thermal switch	96075915
SEG.40.40.2.50B	3 x 400-415	DOL	10	Thermal switch	96075917
SEG.50.26.2.50B	3 x 400-415	DOL	10	Thermal switch	99274384
SEG.50.31.2.50B	3 x 400-415	DOL	10	Thermal switch	99274386
SEG.50.40.2.50B	3 x 400-415	DOL	10	Thermal switch	99274388

5.1.2 SEG standard, Norway

Pump type	Supply voltage [V]	Starting method	Cable length [m]	Thermal protection	Product number
SEG.40.09.2.50C	3 x 230-240	DOL	10	Thermal switch	96075919
SEG.40.12.2.50C	3 x 230-240	DOL	10	Thermal switch	96075920
SEG.40.15.2.50C	3 x 230-240	DOL	10	Thermal switch	96075921
SEG.40.26.2.50C	3 x 230-240	DOL	10	Thermal switch	96075922
SEG.40.31.2.50C	3 x 230-240	DOL	10	Thermal switch	96075923
SEG.40.40.2.50C	3 x 230-240	DOL	10	Thermal switch	96075924
SEG.50.26.2.50C	3 x 230-240	DOL	10	Thermal switch	99274390
SEG.50.31.2.50C	3 x 230-240	DOL	10	Thermal switch	99274391
SEG.50.40.2.50C	3 x 230-240	DOL	10	Thermal switch	99274392

5.1.3 Explosion-proof SEG pumps

5.1.3.1 SEG Ex

Pump type	Supply voltage [V]	Starting method	Cable length [m]	Thermal protection	Product number
SEG.40.09.Ex.2.1.502	1 x 230	DOL	10	Thermal switch	96075894
SEG.40.09.Ex.2.50B	3 x 400	DOL	10	Thermal switch	96075898
SEG.40.12.Ex.2.1.502	1 x 230	DOL	10	Thermal switch	96075902
SEG.40.12.Ex.2.50B	3 x 400	DOL	10	Thermal switch	96075906
SEG.40.15.Ex.2.1.502	1 x 230	DOL	10	Thermal switch	98280725
SEG.40.15.Ex.2.50B	3 x 400	DOL	10	Thermal switch	96075910
SEG.40.26.Ex.2.50B	3 x 400	DOL	10	Thermal switch	96075914
SEG.40.31.Ex.2.50B	3 x 400	DOL	10	Thermal switch	96075916
SEG.40.40.Ex.2.50B	3 x 400	DOL	10	Thermal switch	96075918
SEG.50.26.EX.2.50B*	3 x 400-415	DOL	10	Thermal switch	99274385
SEG.50.31.EX.2.50B*	3 x 400-415	DOL	10	Thermal switch	99274387
SEG.50.40.EX.2.50B*	3 x 400-415	DOL	10	Thermal switch	99274389

* Not yet released. For more information, contact Grundfos.

For accessories, see [Accessories](#).

5.1.3.2 SEG Ex, Australia

Pump type	Supply voltage [V]	Starting method	Cable length [m]	Thermal protection	Product number
SEG.40.09.Ex.2.1.502	1 x 230	DOL	10	Thermal switch	96076161
SEG.40.09.Ex.2.50B	3 x 400-415	DOL	10	Thermal switch	96076162
SEG.40.12.Ex.2.1.502	1 x 230	DOL	10	Thermal switch	96076163
SEG.40.12.Ex.2.50B	3 x 400-415	DOL	10	Thermal switch	96076164
SEG.40.15.Ex.2.50B	3 x 400-415	DOL	10	Thermal switch	96076165
SEG.40.26.Ex.2.50B	3 x 400-415	DOL	10	Thermal switch	96076166
SEG.40.31.Ex.2.50B	3 x 400-415	DOL	10	Thermal switch	96076167
SEG.40.40.Ex.2.50B	3 x 400-415	DOL	10	Thermal switch	96076168
SEG.50.26.Ex.2.50B*	3 x 400-415	DOL	10	Thermal switch	99274393
SEG.50.31.Ex.2.50B*	3 x 400-415	DOL	10	Thermal switch	99274394
SEG.50.40.Ex.2.50B*	3 x 400-415	DOL	10	Thermal switch	99274395

* Not yet released. For more information, contact Grundfos.

For accessories, see [Accessories](#).

5.1.4 SEG AUTO_{ADAPT} pumps

Pump type	Supply voltage [V]	Starting method	Cable length [m]	Thermal protection	Product number
SEG.40.09.E.2.1.502	1 x 230	DOL	10	Thermal switch	96878505
SEG.40.09.E.2.50B	3 x 400-415	DOL	10	Thermal switch	96878506
SEG.40.12.E.2.1.502	1 x 230	DOL	10	Thermal switch	96878509
SEG.40.12.E.2.50B	3 x 400-415	DOL	10	Thermal switch	96878510
SEG.40.15.E.2.1.502	1 x 230	DOL	10	Thermal switch	98280726
SEG.40.15.E.2.50B	3 x 400-415	DOL	10	Thermal switch	96878514
SEG.40.26.E.2.50B	3 x 400-415	DOL	10	Thermal switch	96878516
SEG.40.31.E.2.50B	3 x 400-415	DOL	10	Thermal switch	96878518
SEG.40.40.E.2.50B	3 x 400-415	DOL	10	Thermal switch	96878520
SEG.50.26.E.2.50B	3 x 400-415	DOL	10	Thermal switch	99274434
SEG.50.31.E.2.50B	3 x 400-415	DOL	10	Thermal switch	99274436
SEG.50.40.E.2.50B	3 x 400-415	DOL	10	Thermal switch	99274438

5.1.5 Explosion-proof SEG AUTO_{ADAPT} pumps

Pump type	Supply voltage [V]	Starting method	Cable length [m]	Thermal protection	Product number
SEG.40.09.E.Ex.2.1.502	1 x 230	DOL	10	Thermal switch	96878507
SEG.40.09.E.Ex.2.50B	3 x 400	DOL	10	Thermal switch	96878508
SEG.40.12.E.Ex.2.1.502	1 x 230	DOL	10	Thermal switch	96878512
SEG.40.12.E.Ex.2.50B	3 x 400	DOL	10	Thermal switch	96878513
SEG.40.15.E.Ex.2.50B	3 x 400	DOL	10	Thermal switch	96878515
SEG.40.26.E.Ex.2.50B	3 x 400	DOL	10	Thermal switch	96878517
SEG.40.31.E.Ex.2.50B	3 x 400	DOL	10	Thermal switch	96878519
SEG.40.40.E.Ex.2.50B	3 x 400	DOL	10	Thermal switch	96878521
SEG.50.26.E.Ex.2.50B*	3 x 400-415	DOL	10	Thermal switch	99274435
SEG.50.31.E.Ex.2.50B*	3 x 400-415	DOL	10	Thermal switch	99274437
SEG.50.40.E.Ex.2.50B*	3 x 400-415	DOL	10	Thermal switch	99274439

* Not yet released. For more information, contact Grundfos.

For accessories, see [Accessories](#).

6. Variants

6.1 List of variants

Motor		
		15 m
		20 m
Standard cables	Cable B, 4 G 1.5 mm ² + 3 x 1 mm ²	25 m
		30 m
		40 m
		50 m
		15 m
Ex cables	Cable B, 4 G 1.5 mm ² + 3 x 1 mm ² , Ex	20 m
		25 m
		30 m
		40 m
		50 m
Screened power cables for frequency converters	Screened cable B, Ex	10 m
		15 m
		20 m
		25 m
		30 m
		40 m
Cable protection	For 7-core cable	
Moisture switch		
Special motor	Special voltage with or without PTC, etc.	Contact Grundfos

Note: Screened cable is not available for SEG 1.5 kW, 1 phase, Ex pumps.

Tests		
Test at specified duty on standard impeller curve		
Additional test of entire QH curve, including report	5 to 10 flows from pump performance curve	
Different test standard	Efficiency guaranteed by Grundfos	ISO 9906:2012 grade 3B
Witness test	Contact Grundfos	

Note: For customised duty point or other grades with 5 point test certificate, order together with pump.

Certificates		
ATEX-approved pump report	Special Grundfos report. Contact Grundfos.	
Certificate of compliance with order	According to EN 10204 2.1.	
Pump certificate	According to EN 10204 2.2.	
Inspection certificate	According to EN 10204 3.1.	
Material specification report	According to EN 10204 3.1B.	
Material report with certificate	According to EN 10204 3.2.	Material supplier information.
Inspection certificate, Lloyds Register	According to EN 10204 3.2.	
Inspection certificate, DNV (Det Norske Veritas)	According to EN 10204 3.2.	
Inspection certificate, Germanischer Lloyd	According to EN 10204 3.2.	
Inspection certificate, American Bureau of Shipping	According to EN 10204 3.2.	
Inspection certificate, Bureau Veritas	According to EN 10204 3.2.	
Inspection certificate, Registro Italiano Navale Argentina	According to EN 10204 3.2.	
Other third-party test certificate	Contact Grundfos.	

Miscellaneous	
Special packaging	Contact Grundfos.
Special nameplate	Contact Grundfos.
Other variants	Contact Grundfos.
Chemical-resistant shaft seal	FKM, standard (NBR).
Chemical-resistant pump	FKM, standard (NBR).
Internal surface treatment	Extra epoxy (CED) coating.
Top coating	Black NCS 9000N (RAL 9005).
	Other colour.

7. Construction

7.1 Material specification, SEG pumps

The position numbers in the table below refer to the sectional drawings and exploded views on the following pages.

Pos.	Description	Material	EN standard	AISI/ASTM
6a	Pin	Stainless steel	-	-
7a	Rivet	Stainless steel	-	-
9a	Key	Stainless steel	-	-
26a	O-ring	NBR		
37	O-ring	NBR		
37a	O-rings	NBR	-	-
44	Grinder ring	Stainless steel	1.4542	630
45	Grinder head	Stainless steel	1.4542	630
48	Stator	-	-	-
48a	Terminal board			
49	Impeller	Cast iron	EN-GJL-200	A48 30B
50	Pump housing	Cast iron	EN-GJL-200	A48 30B
55	Stator housing	Cast iron	EN-GJL-200	A48 30B
58	Shaft seal retainer	Cast iron	EN-GJL-200	A48 30B
66	Locking ring	Stainless steel	-	-
68	Adjusting nut	Stainless steel	1.4057	431
76	Nameplate	Stainless steel	1.4301	304
92	Clamp	Stainless steel	1.4301	304
102	O-ring	NBR	-	-
103	Bush	Stainless steel	1.4057	431
104	Seal ring	NBR	-	-
105	Shaft seal	Primary seal (0.9 to 1.5 kW): SiC/SiC Secondary seal (0.9 to 1.5 kW): lip seal, NBR Primary seal (2.6 to 4.0 kW): SiC/SiC Secondary seal (2.6 to 4.0 kW): carbon/aluminum oxide Other components: NBR, stainless steel	-	-
107	O-rings	NBR	-	-
112a	Locking ring	Stainless steel	-	-
150a	Stator in housing complete	-	-	-
153	Bearing, lower	Up to and including 1.5 kW: 6303 2.6 kW and up: 3205	-	-
153a	Lock washer	Stainless steel	-	-
153b	Locking ring	Stainless steel	-	-
154	Bearing	Up to and including 1.5 kW: 6201 2.6 kW and up: 6205	-	-
155	Oil chamber	-	-	-
158	Corrugated spring	Steel	-	-
159	O-ring	NBR	-	-
172	Rotor/shaft	Shaft part at rotor: steel Shaft end at hydraulics: stainless steel	1.0533 1.4301	304
173	Screw	Steel	-	-
173a	Washer	Steel	-	-
176	Inner plug part	PET	-	-
181	Outer plug part	CR rubber, cable H07RN-F	1.4308	CF-8
188a	Screw	Stainless steel	-	-
190	Lifting bracket	Stainless steel	1.4308	CF-8

Pos.	Description	Material	EN standard	AISI/ASTM
193	Oil screw	Stainless steel	-	-
193a	Oil	Shell Ondina X420	-	-
194	Gasket	Nylon	-	-
198	O-ring	NBR	-	-
199	O-ring	NBR	-	-
	Paint	Two-component epoxy	-	-

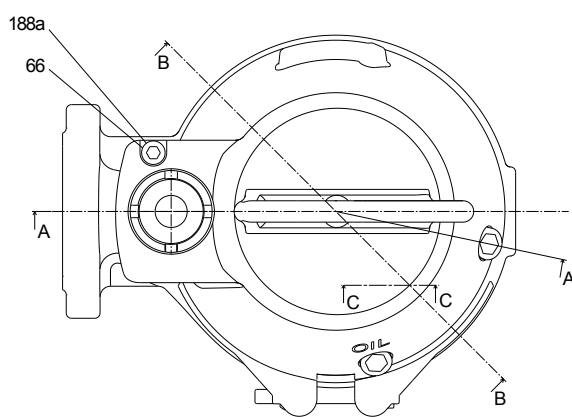
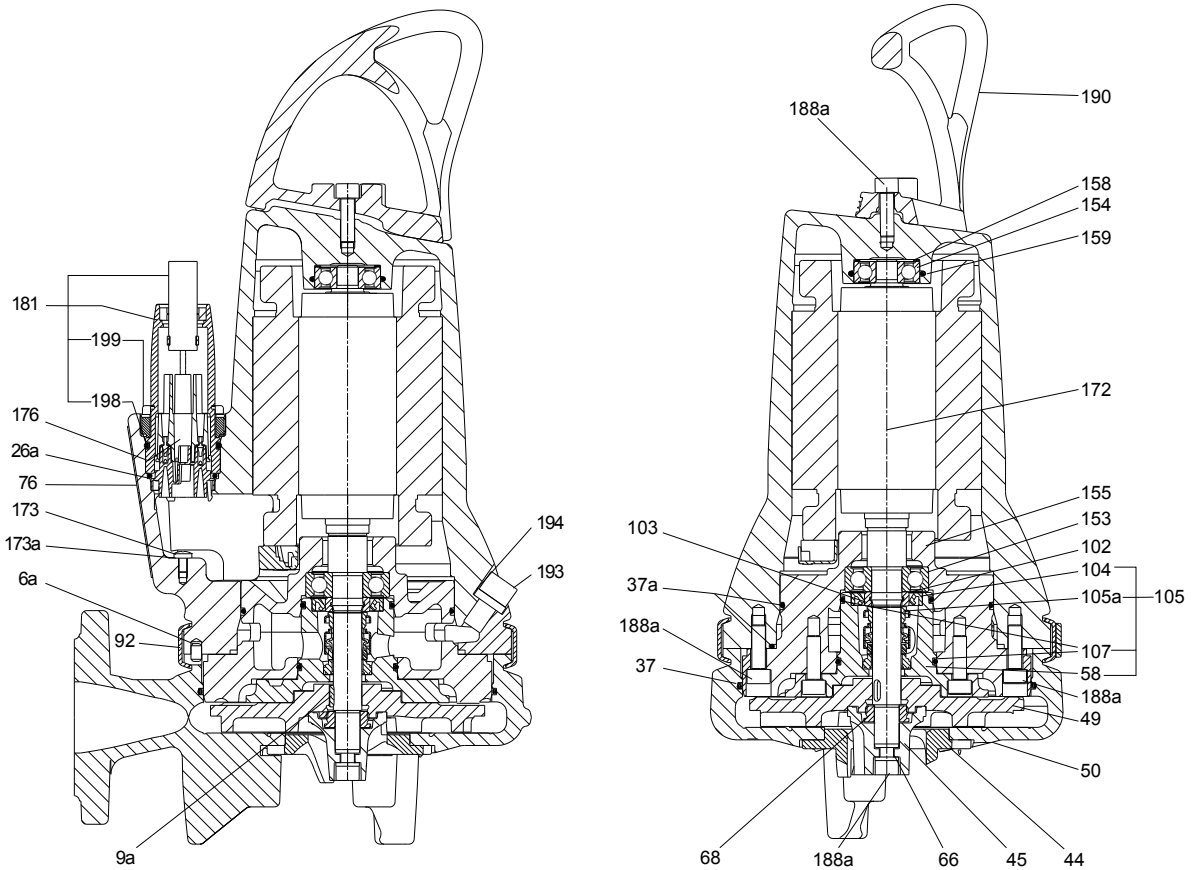

C - C

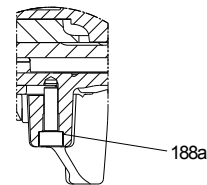

TM066108

Sectional drawing of SEG pumps, 0.9, 1.2 and 1.5 kW

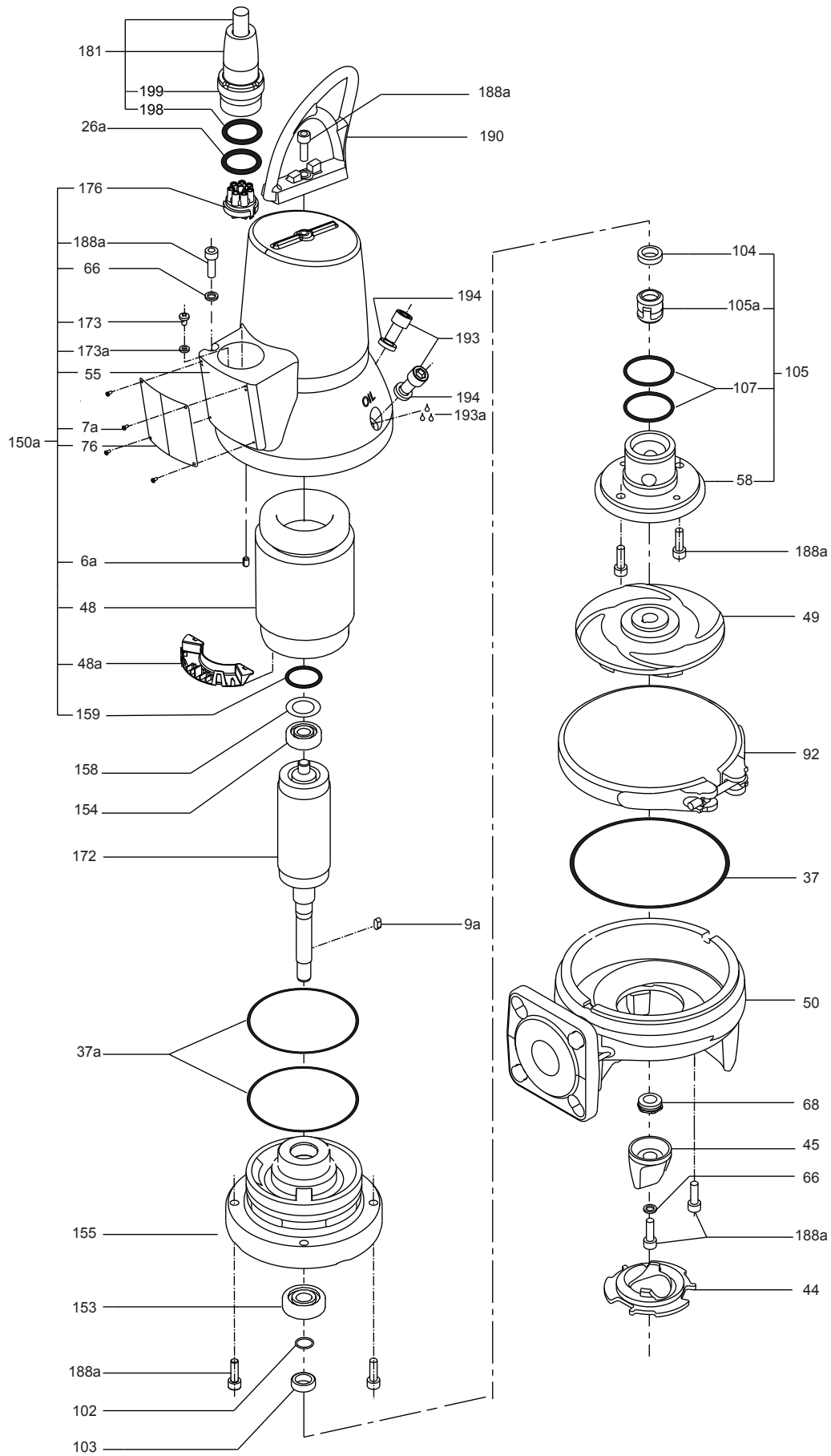

TM065739

Exploded view of SEG pumps, 0.9, 1.2 and 1.5 kW

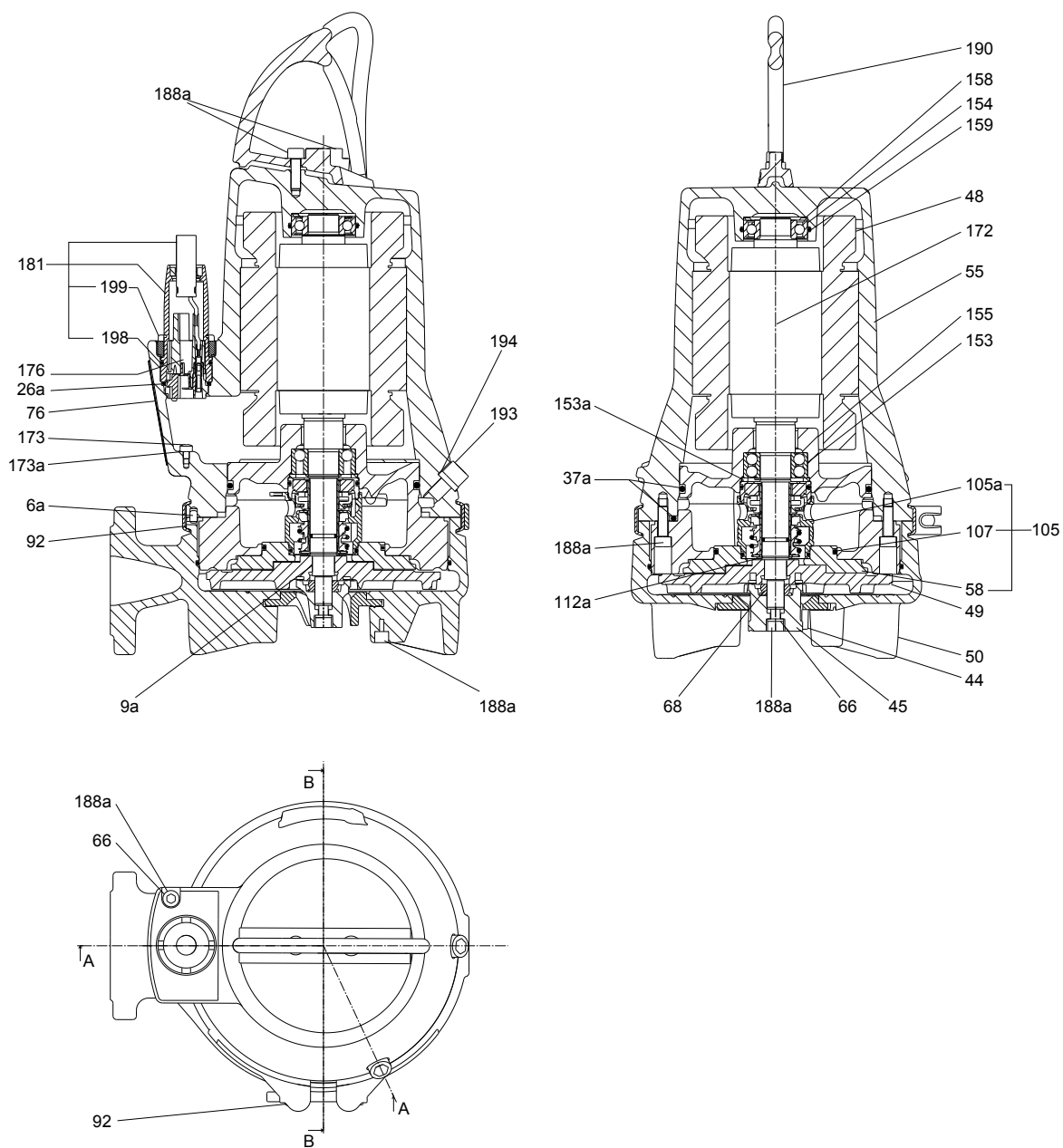

Sectional drawing of SEG pumps, 2.6, 3.1 and 4.0 kW

TM066110

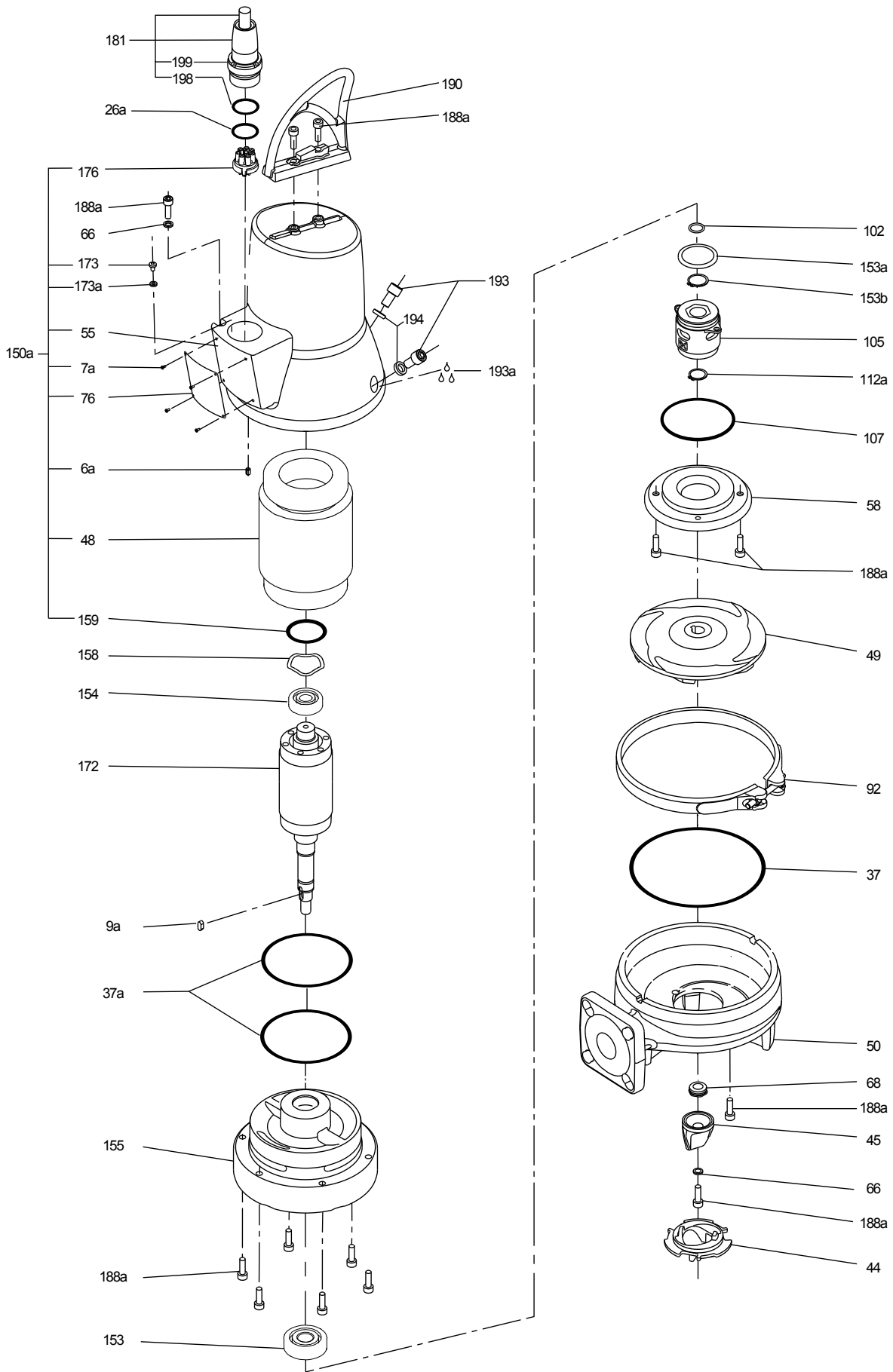

TM065759

Exploded view of SEG pumps, 2.6, 3.1 and 4.0 kW

7.2 Material specification, SEG AUTO_{ADAPT} pumps

The position numbers in the table below refer to the sectional drawings and exploded views on the following pages.

Pos.	Description	Material	EN standard	AISI/ASTM
6a	Pin	Stainless steel	-	-
7a	Rivet	Stainless steel	-	-
9a	Key	Stainless steel	-	-
26a	O-ring	NBR		
37	O-ring	NBR		
37a	O-rings	NBR	-	-
44	Grinder ring	Stainless steel	1.4542	630
45	Grinder head	Stainless steel	1.4542	630
48	Stator	-	-	-
48a	Terminal board	-	-	-
49	Impeller	Cast iron	EN-GJL-200	A48 30B
50	Pump housing	Cast iron	EN-GJL-200	A48 30B
55	Stator housing	Cast iron	EN-GJL-200	A48 30B
58	Shaft seal retainer	Cast iron	EN-GJL-200	A48 30B
66	Locking ring	Stainless steel	-	-
68	Adjusting nut	Stainless steel	1.4057	431
76	Nameplate	Stainless steel	1.4301	304
90a	Electronic unit	-	-	-
90b	O-ring	-	-	-
92	Clamp	Stainless steel	1.4301	304
102	O-ring	NBR	-	-
103	Bush	Stainless steel	1.4057	431
104	Seal ring	NBR	-	-
105/105a	Shaft seal	Primary seal (0.9 to 1.5 kW): SiC/SiC Secondary seal (0.9 to 1.5 kW): lip seal, NBR Primary seal (2.6 to 4.0 kW): SiC/SiC Secondary seal (2.6 to 4.0 kW): carbon/aluminium oxide Other components: NBR, stainless steel	-	-
107	O-rings	NBR	-	-
112a	Locking ring	Stainless steel	-	-
153	Bearing, lower	Up to and including 1.5 kW: 6303 2.6 kW and up: 3205	-	-
153a	Lock washer	Stainless steel	-	-
153b	Locking ring	Stainless steel	-	-
154	Bearing, top	Up to and including 1.5 kW: 6201 2.6 kW and up: 6205	-	-
155	Oil chamber	-	-	-
158	Corrugated spring	Steel	-	-
159	O-ring	NBR	-	-
161b	Pt1000 sensor with bracket	-	-	-
161c	Run capacitor and Pt1000 sensor with bracket *	-	-	-
172	Rotor/shaft	Shaft part at rotor: steel Shaft end at hydraulics: stainless steel	1.0533 1.4301	304 -
173	Screw	Steel	-	-
173a	Washer	Steel	-	-
174	Earth screw	-	-	-
174a	Washer	-	-	-
176	Inner plug part	PET	-	-
181	Outer plug part	CR rubber, cable H07RN-F	1.4308	CF-8
188a	Screw	Stainless steel	-	-
190	Lifting bracket	Stainless steel	1.4308	CF-8

Pos.	Description	Material	EN standard	AISI/ASTM
193	Oil screw	Stainless steel	-	-
193a	Oil	Shell Ondina X420	-	-
194	Gasket	Nylon	-	-
198	O-ring	NBR	-	-
199	O-ring	NBR	-	-
285	Dry-running sensors **	-	1.4404	-
285a	O-ring	NBR	-	-
285b	Set screw	-	-	-
287	Level sensor	-	1.4404	-
287b	O-ring	-	-	-
287c	Set screw	-	-	-
532	Silica gel	-	-	-
	Paint	Two-component epoxy	-	-

* Single-phase pumps only.

** Explosion-proof pumps have two dry-running sensors.

Single-phase pumps only

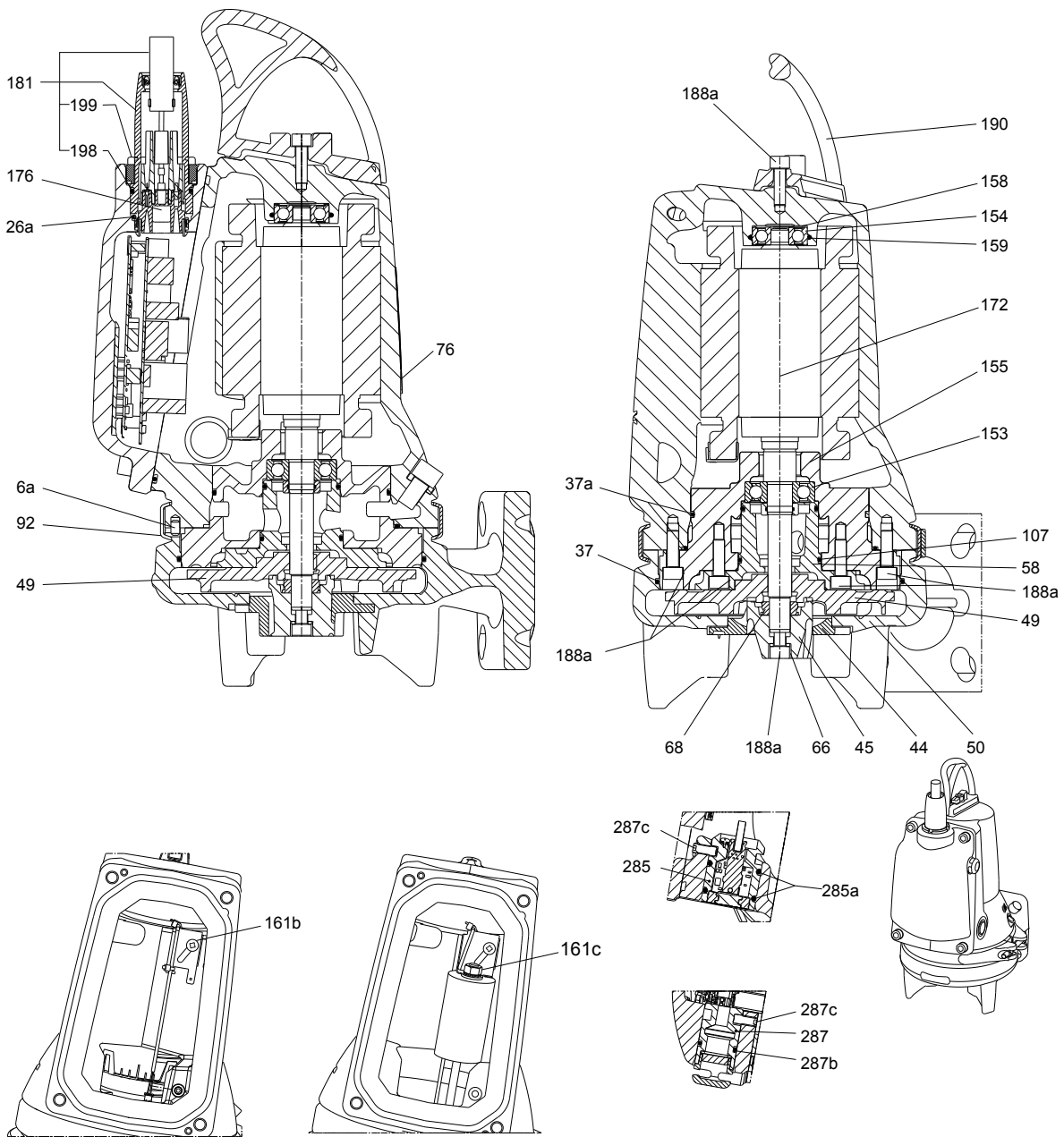

TM066109

Sectional drawing of SEG AUTO_{ADAPT} pumps, 0.9, 1.2 and 1.5 kW

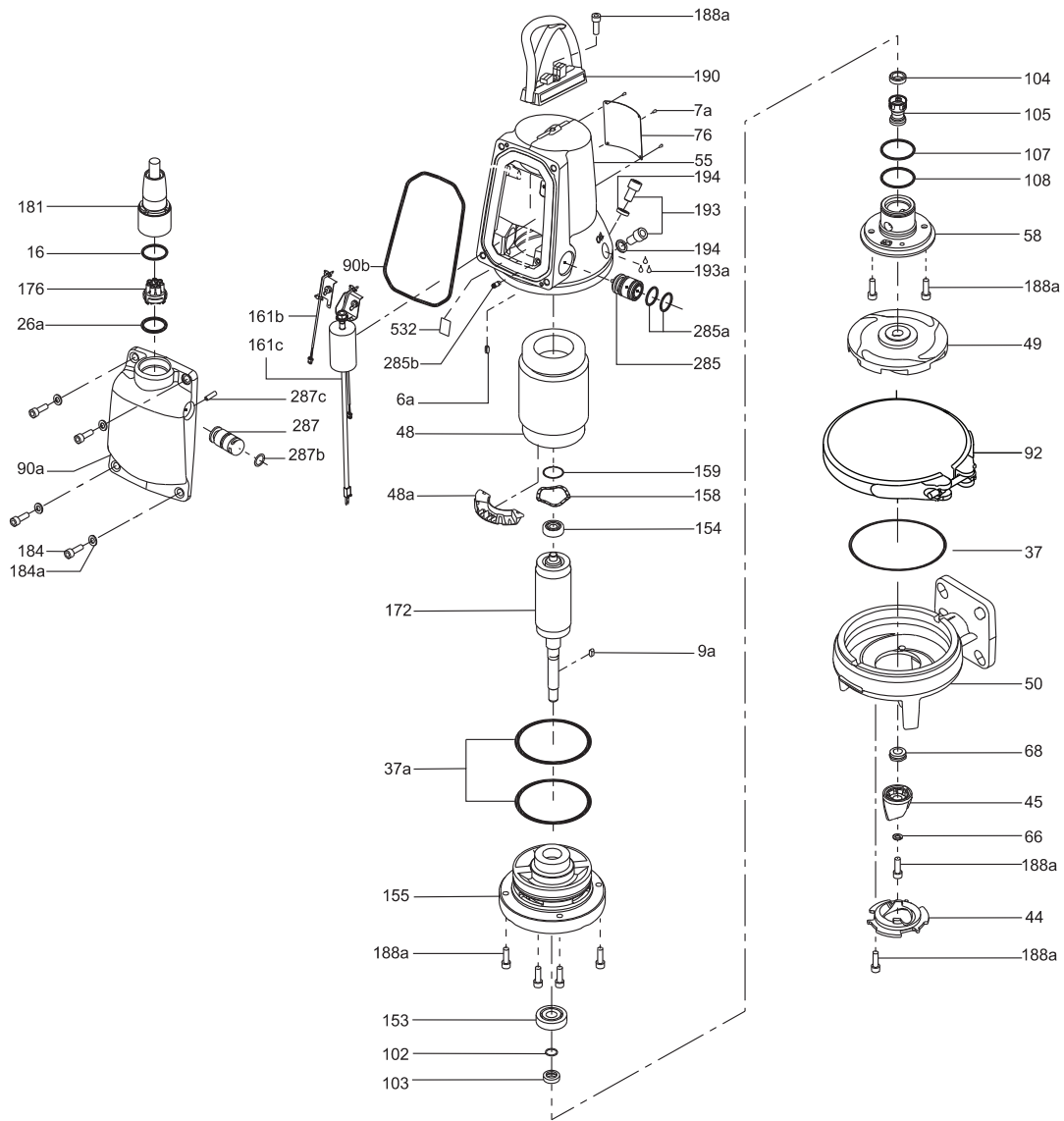

Exploded view of SEG AUTO_{ADAPT} pumps, 0.9, 1.2 and 1.5 kW

TM065750

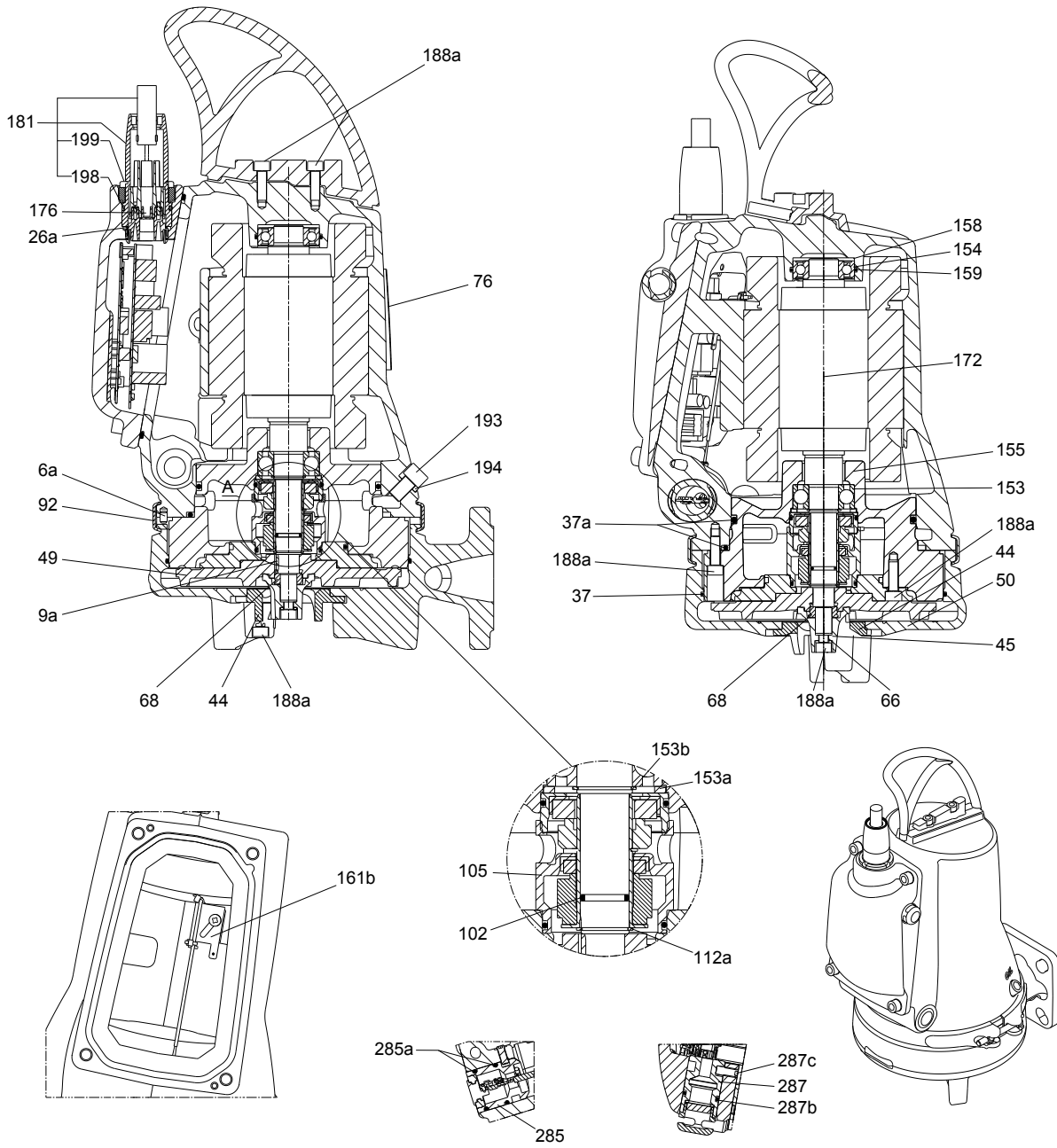

TM066111

Sectional drawing of SEG AUTO_{ADAPT} pumps, 2.6, 3.1 and 4.0 kW

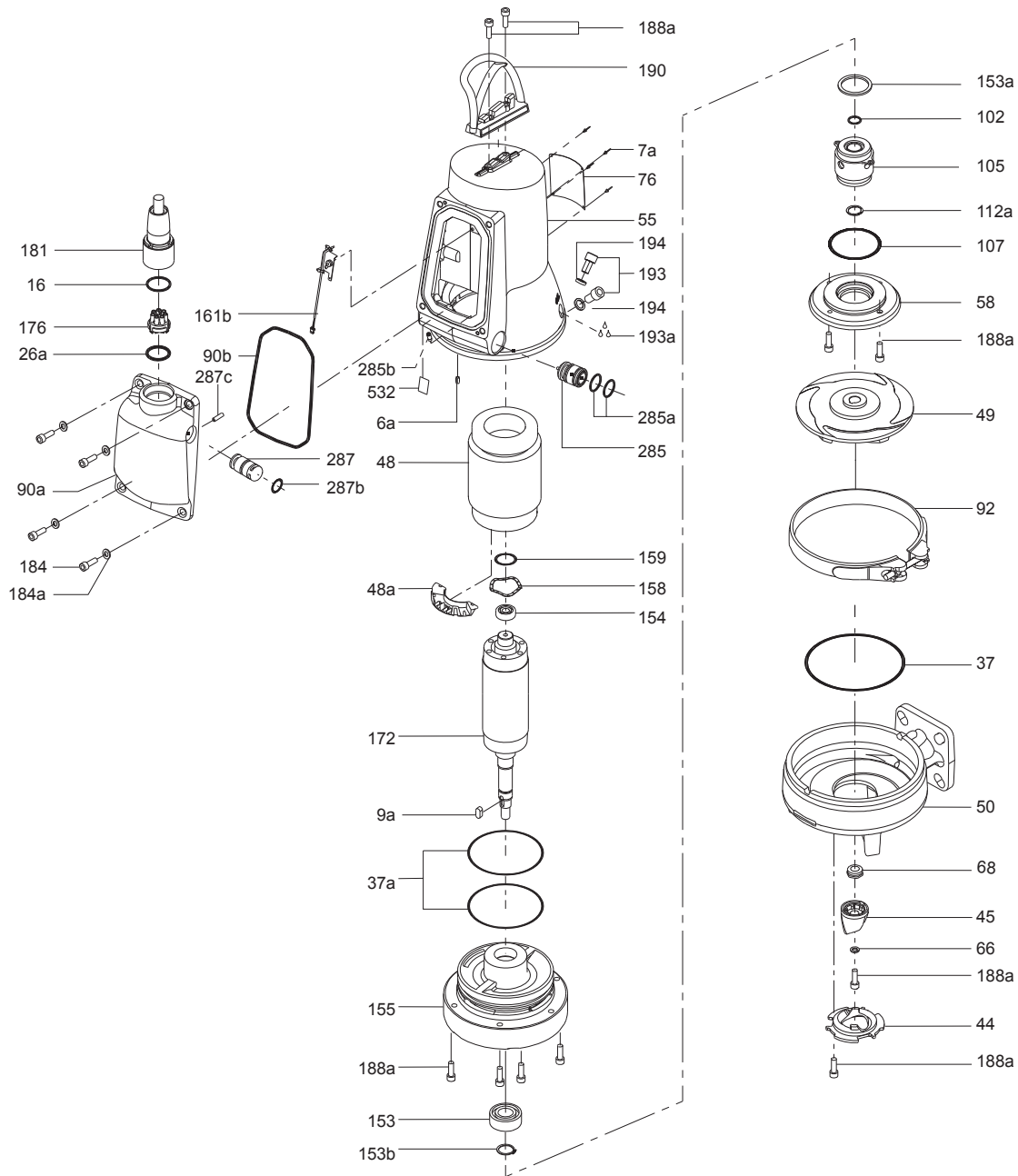

Exploded view of SEG AUTO_{ADAPT} pumps, 2.6, 3.1 and 4.0 kW

TM065770

8. Product description

8.1 Features

8.1.1 Ball bearings

The ball bearings are greased for life.

Top bearings:

- Up to and including 1.5 kW: Single-row ball bearing 6301.
- 2.6 kW and up: Single-row ball bearing 6205.

Bottom bearings:

- Up to and including 1.5 kW: Single-row ball bearing 6303.
- 2.6 kW and up: Angular-contact ball bearing 3205.

8.1.2 Shaft seal

The SEG range is available with two shaft seal variants. Both variants are fitted as cartridge seals. The shaft seal separates the motor from the pumped liquid.

Pumps up to and including 1.5 kW have a silicon carbide/silicon carbide (SiC/SiC) mechanical shaft seal as primary seal and a lip seal as secondary seal. In connection with service, the mechanical shaft seal and the lip seal are supplied as one unit ready for fitting.

Pumps of 2.6 kW and up have a double shaft seal consisting of a SiC/SiC mechanical shaft seal as primary seal and a carbon/aluminium oxide mechanical shaft seal as secondary seal.

8.1.3 Motor

The motor is a watertight, totally encapsulated motor.

Insulation class: F (155 °C).

Temperature class: F (105 °C).

Enclosure class: IP68.

For motor protection and sensors, see Sensors.

Related information

[8.1.7 Sensors](#)

8.1.4 Surface treatment

Grundfos SEG and SEG AUTO_{ADAPT} are given the following surface treatment:

- cathoresis treatment for all cast iron parts
- powder coating: NCS 9000 N (black), gloss code 30, thickness of minimum 100 µm and maximum 200 µm.

8.1.5 Power cables

Standard cable

Cable type	Outer cable diameter [mm]	Bending radius	
		Fixed	Free
Lyniflex 4 G 1.5 mm ² + 3 x 1 mm ²	15.5 ± 0.5	60	90

EMC cable

Cable type	Outer cable diameter [mm]	Bending radius	
		Fixed	Free
3G3GC3G-F3x1AiC+4 G 2.5 mm ²	17.5 ± 0.5	85	170

As standard, the cables are 10 m long. Other cable lengths are available on request. See List of variants. The number and dimensions of cables depend on the motor size.

Related information

[6.1 List of variants](#)

8.1.6 Cable entry

The stainless-steel plug is fastened with a union nut. The nut and O-rings provide sealing against ingress of liquid.

The plug is filled with a special polyurethane potting compound that is cast into the plug around the leads of the cable. This prevents the ingress of liquid into the motor through the cable in case of cable breakage or rough handling in connection with installation or service.

8.1.7 Sensors

SEG

As standard, the pump has two thermal switches incorporated in the motor windings to protect the motor against overheating.

SEG AUTO_{ADAPT}

As standard, the pump incorporates the following:

- One analog absolute-pressure transmitter.
- One dry-running sensor. Explosion-proof versions have two dry-running sensors. The dry-running sensor(s) is (are) used for indicating the stop level in the first pump cycle and to prevent dry running. On standard versions, the dry-running sensor can be overruled by an optional Communication Interface Unit (CIU) unit if there is a risk of a floating layer.
- Two sets of thermal switches incorporated in the stator windings to protect the motor against overheating.
- Two Pt1000 sensors for analog measurement.
- Built-in motor protection I² (t) as extra safety.

8.2 Operating conditions

The pumps are designed for intermittent operation (S3). When completely submerged, the pumps can also operate continuously (S1).

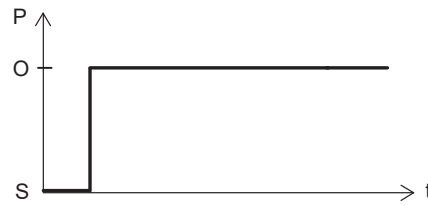
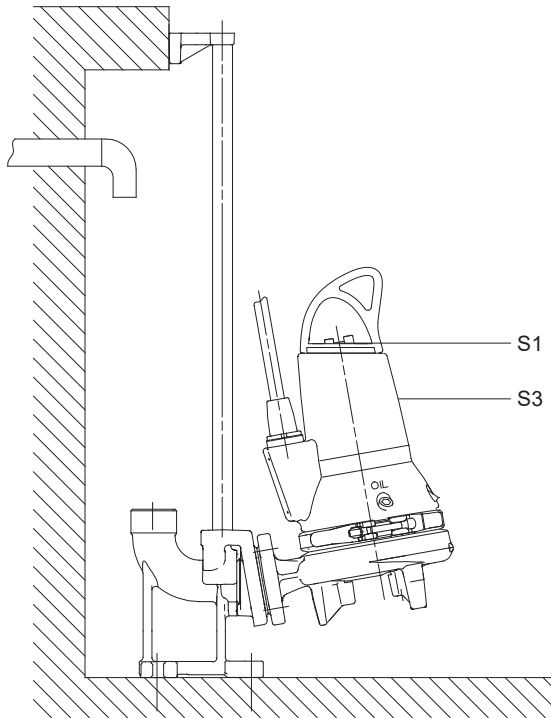

TM044528

S1 operation

Pos.	Description
O	Operation
S	Stop

Operation levels

S3, intermittent operation

S3 operation is a series of identical duty cycles (TC) each with a constant load for a period, followed by a rest period. Thermal equilibrium is not reached during the cycle. See fig. S3 operation.

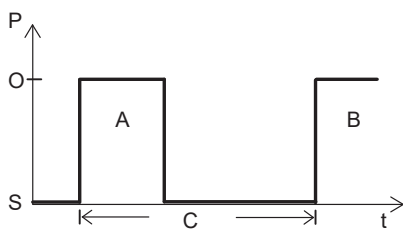

TM044527

S3 operation

Pos.	Description
O	Operation
S	Stop

S1, continuous operation

In this operating mode, the pump can operate continuously without having to be stopped for cooling. Being completely submerged, the pump is sufficiently cooled by the surrounding liquid. See fig. S1 operation.

8.2.1 Pumped liquids

pH value: 4-14.

Liquid temperature: 0-40 °C.

When pumping liquids with a density and/or a kinematic viscosity higher than that of water, use motors with correspondingly higher outputs.

For short periods of maximum 3 minutes, temperatures up to 60 °C are allowed (non-Ex versions only).

Sound pressure level

The sound pressure level of the pump is lower than the limiting values stated in the EC Machinery Directive (2006/42/EC).

8.3 Motor range

Output power [kW]	Number of poles
0.9	2
1.2	2
1.5	2
2.6	2
3.1	2
4.0	2

All SEG and SEG AUTO_{ADAPT} pump motors fulfil the requirements of IEC 30034 and 30335 (except 60335-2-41, clause 25.8), and all motors have a reserve capacity of 10 % as standard.

8.4 Frequency converter operation

This section applies to SEG pumps only.

Note: The SEG AUTO_{ADAPT} pumps must not be used with a frequency converter.

In principle, all three-phase pumps can be connected to a frequency converter.

However, frequency converter operation will often expose the motor insulation system to a heavier load and cause the motor to be more noisy than usual due to eddy currents caused by voltage peaks.

In addition, large motors driven via a frequency converter will be loaded by bearing currents.

Frequency converter operation will also influence the efficiency of the grinder system.

To avoid the risk of sedimentation in the pipes, we recommend that you operate the speed-controlled pump within a speed range of 30-100 % and at a flow rate above 1 m/s.

For more information, see the installation and operating instructions for the relevant frequency converter in Grundfos Product Center at www.grundfos.com.

8.5 Approvals

The standard version of SEG pumps has been tested by VDE.

The explosion-proof version of SEG and the SEG AUTO_{ADAPT} pumps has been approved by DEKRA according to the ATEX directive.

Approval standards

The standard SEG and all SEG AUTO_{ADAPT} versions are approved by TÜV Rheinland LGA according to EN 12050-1. LGA is a notified body under the Construction Products Directive.

Ex approval

The explosion protection classification of the SEG pump is Europe CE 0344 Ⓜ II 2 G Ex db IIB T4 Gb.

The explosion protection classification of the SEG AUTO_{ADAPT} pump is Europe CE 0344 Ⓜ II 2 G Ex h db ib IIB T4 Gb.

Directive/standard	Code	Description
ATEX	CE 0344	= CE mark of conformity according to the ATEX directive 2014/34/EU. 0344 is the number of the notified body which has certified the quality system for ATEX.
	Ⓜ	= Explosion protection mark.
	II	= Equipment group according to the ATEX directive, defining the requirements applicable to the equipment in this group.
	2	= Equipment category according to the ATEX directive, defining the requirements applicable to the equipment in this category.
Harmonised European standard	G	= Explosive atmospheres caused by gases, vapours or mists.
	Ex	= The equipment conforms to the harmonised European standard.
	h	= Non-electrical equipment for explosive atmosphere.
	db	= Flame-proof enclosure according to EN 60079-1.
	ib	= Intrinsic safety.
	IIB	= Classification of gases according to EN 60079-0. Gas group B includes gas group A.
	T4	= Maximum surface temperature is 135 °C.
	Gb	= Equipment for explosive gas atmosphere with "high" level of protection.

Australia

For IEC countries, such as Australia and others, the explosion-proof versions of SEG pumps have been approved by DEKRA, certificate no IECEx 06.0028X, according to IEC 60079-15:1987, corresponding to AS 2380.9.

The explosion-protection classification of the pumps is Ex nC II T3 Gb.

Directive/standard	Code	Description
IEC 60079-15	Ex	= Area classification according to AS 2430.1
	n	= Non-sparking according to AS2380.9:1991, section 3 (IEC 60079-15).
	C	= The environment is adequately protected against sparking components.
	II	= Suitable for use in explosive atmospheres (not mines).
	T3	= The maximum surface temperature is 200 °C.

For IEC countries, such as Australia and others, the explosion-proof versions of SEG AUTO_{ADAPT} pumps have been approved by DEKRA, certificate no IECEx DEK 11.0026X.

The explosion-protection classification of the pumps is Ex db ib IIB T4 Gb.

Directive/standard	Code	Description
IEC 60079-0:2011, IEC 60079-1:2014 and IEC 60079 11:2011	Ex	= The equipment conforms to the IECEx.
	db	= Flame-proof enclosure.
	ib	= Intrinsic safety.
	IIB	= Classification of gases. Gas group B includes gas group A.
	T4	= The maximum surface temperature is 135 °C.
	Gb	= Equipment for explosive gas atmosphere with "high" level of protection.

8.6 Wiring diagrams

125 °C, 135 °C below apply to single-phase, 1.5 kW, pumps

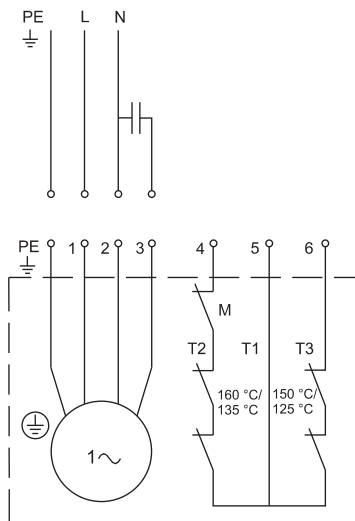

Wiring diagram for single-phase SEG pumps. See table below.

Pump type [kW]	Cs, starting capacitor		Cr, run capacitor	
	[μF]	[V]	[μF]	[V]
0.9, 1.2	150	230	30	450
1.5	150	230	40	450

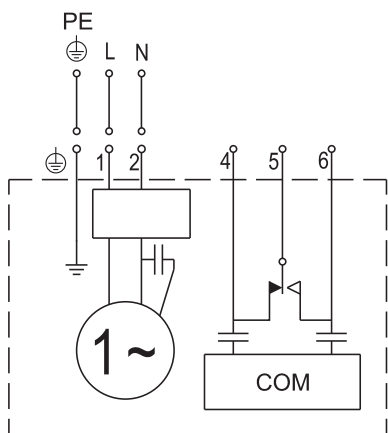

Wiring diagram for single-phase SEG AUTOADAPT pumps

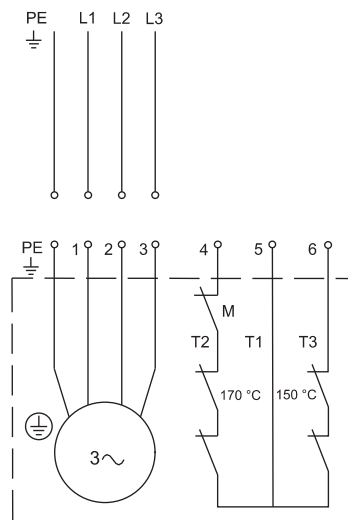

Wiring diagram for three-phase SEG pumps

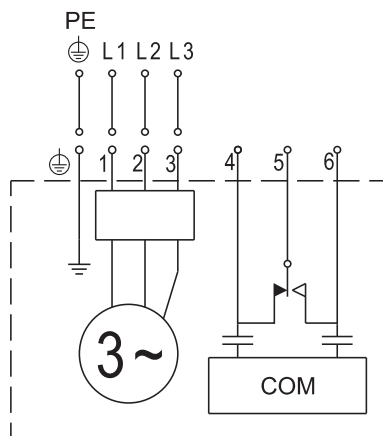

Wiring diagram for three-phase SEG AUTOADAPT pumps

TM065691

TM065692

TM044297

TM044298

9. Curve charts

9.1 How to read the performance curves

The curves on the following pages apply to both SEG and SEG AUTO_{ADAPT} pumps as well as the explosion-proof versions.

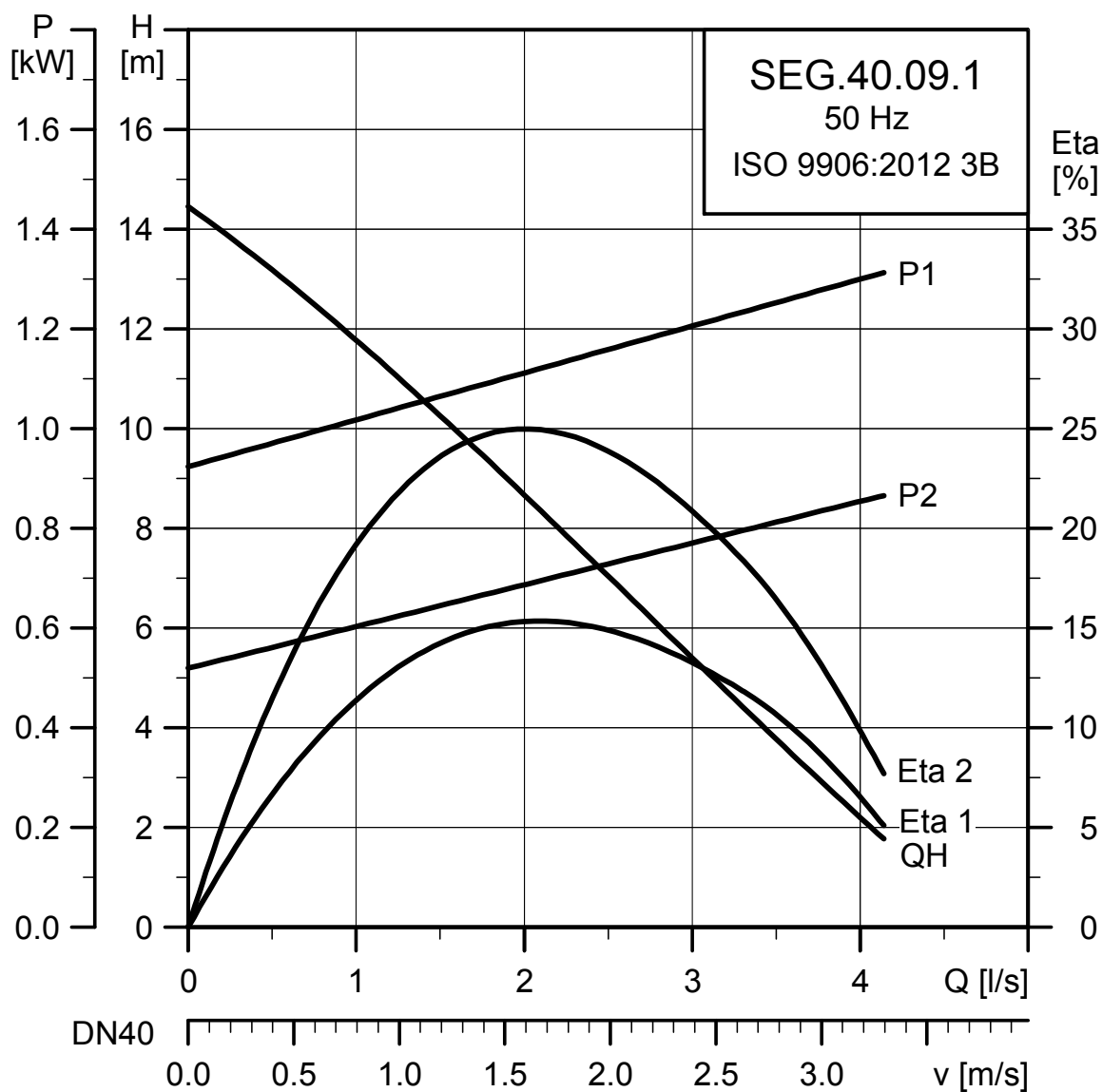

TM025270

Pos.	Description
H	Total pump head $H = H_{total}$
QH	QH curve
P1, P2	Power curves indicating input power (P_1) and output power (P_2) of the pump shown.
Eta1	Eta 1 is the total efficiency (pump and motor)
Eta2	Eta 2 is the hydraulic efficiency (pumps)

Note: The pumps are tested according to ISO 9906:2012 grade 3B tolerance. Testing equipment and measuring instruments are designed and calibrated according to the standards mentioned. The pumps are approved according to tolerances for entire curves, specified in grade 3B.

9.2 Curve conditions

The guidelines below apply to the performance curves in [10. Performance curves and technical data](#).

- Tolerances are according to ISO 9906:2012 3B.
- The curves show the pump performance with different impeller diameters at the rated speed.
- The curves apply to the pumping of airless water at a temperature of +20 °C and a kinematic viscosity of 1 mm²/s (1 cSt).
- The Eta curves show the efficiency of the pump for the different impeller diameters.
- The NPSH curves show average values measured under the same conditions as the performance curves. When sizing the pump, add a safety margin of at least 0.5 m.
- In the case of other densities than 1000 kg/m³, the outlet pressure is proportional to the density.
- When pumping liquids with a density higher than 1000 kg/m³, use motors with correspondingly higher outputs.

Calculation of total head

The total pump head consists of the height difference between the measuring points + the differential head + the dynamic head.

$$H_{\text{total}} = H_{\text{geo}} + H_{\text{stat}} + H_{\text{dyn}}$$

H_{geo} :	Height difference between measuring points.
H_{stat} :	Differential head across the pump.
H_{dyn} :	Calculated values based on the velocity of the pumped liquid on the inlet and outlet sides of the pump.

9.3 Performance tests

The requested duty point of every pump is tested according to ISO 9906:2012 3B, and without certification. In the case of pumps ordered on the basis of impeller diameter only (no requested duty point), the pump will be tested at a duty point which is 2/3 of the maximum flow of the published performance curve which is related to the ordered impeller diameter (according to ISO 9906:2012 3B).

If the customer requires either more points on the curve to be checked or certain minimum performances or certificates, individual measurements must be made, and a certificate can be ordered.

9.4 Certificates

Certificates must be confirmed for every order and are available on request. See [6.1 List of variants](#).

Related information

[6.1 List of variants](#)

9.5 Witness test

It is possible for the customer to witness the testing procedure according to ISO 9906:2012 3B.

The witness test is not a certificate and will not result in a written statement from Grundfos. The witness test itself is the only guarantee that everything is carried out as prescribed in the testing procedure.

If the customer wants to witness the test of the pump performance, this request must be stated on the order.

10. Performance curves and technical data

10.1 SEG.40

10.1.1 SEG.40.09.(E).(Ex).2.1.502

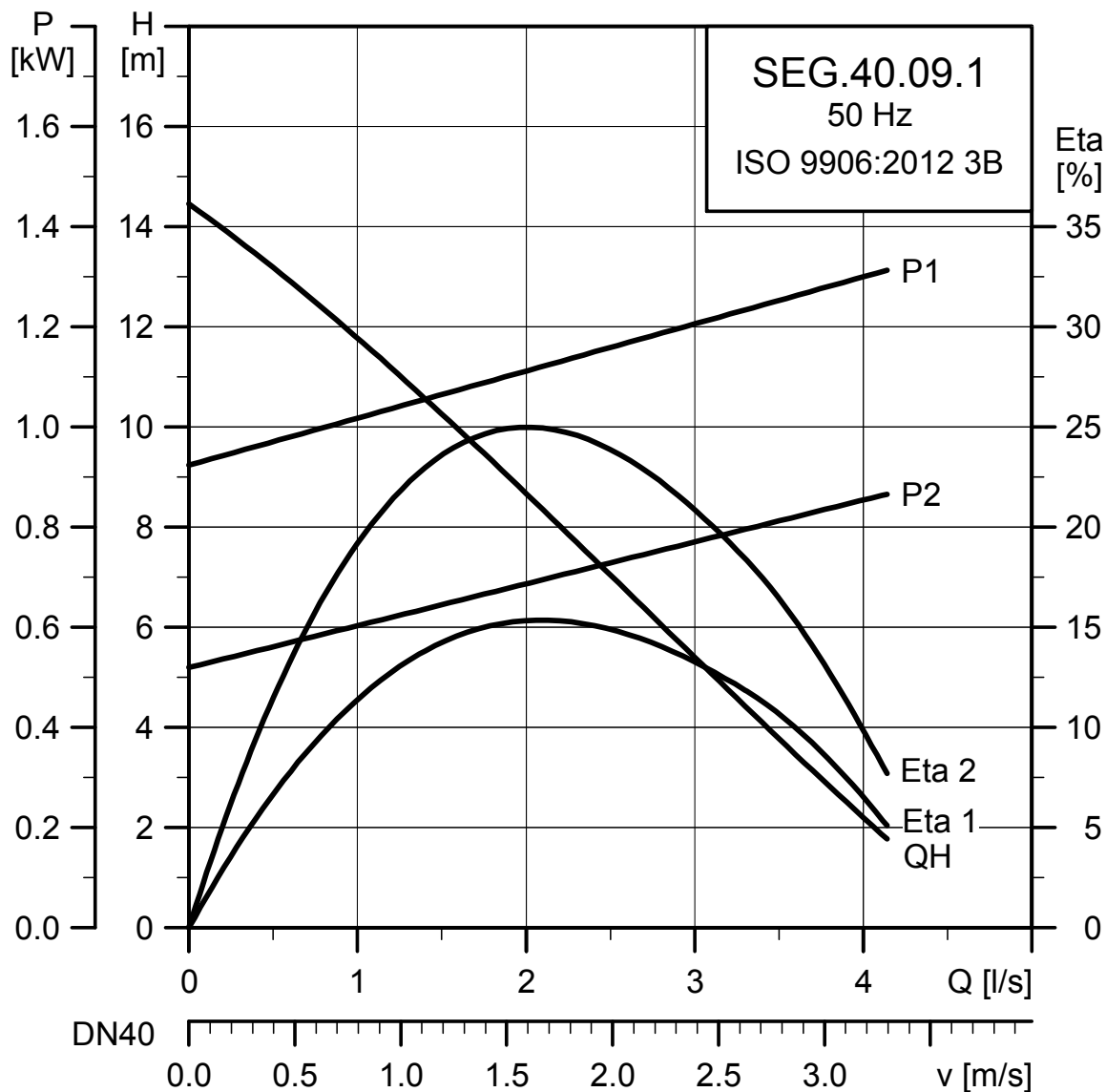

TM025270

Electrical data

Voltage [V]	P1 [kW]	P2 [kW]	Number of poles	min ⁻¹	Starting method	I _N			I _{start}			η _{motor} [%]			Cos φ		Moment of inertia [kgm ²]	Breakdown torque M _{max.} [Nm]
						[A]	[A]	[A]	1/2	3/4	1/1	1/2	3/4	1/1				
1 x 230	1.4	0.9	2	2890	DOL	5.8	38	58	67	71	0.94	0.98	0.99	0.0036	7			

Pump data

Impeller type	Maximum solids size	Maximum number of starts per hour	Maximum installation depth	Enclosure class	Insulation class	Maximum liquid temperature	pH	Ex class
	[mm]		[m]			[°C]		
Semi-open	Grinder system	30	10	IP68	F	40	4-14	EEX d IIB T4 Class I Zone II

10.1.2 SEG.40.09.(E).(Ex).2.50B/C

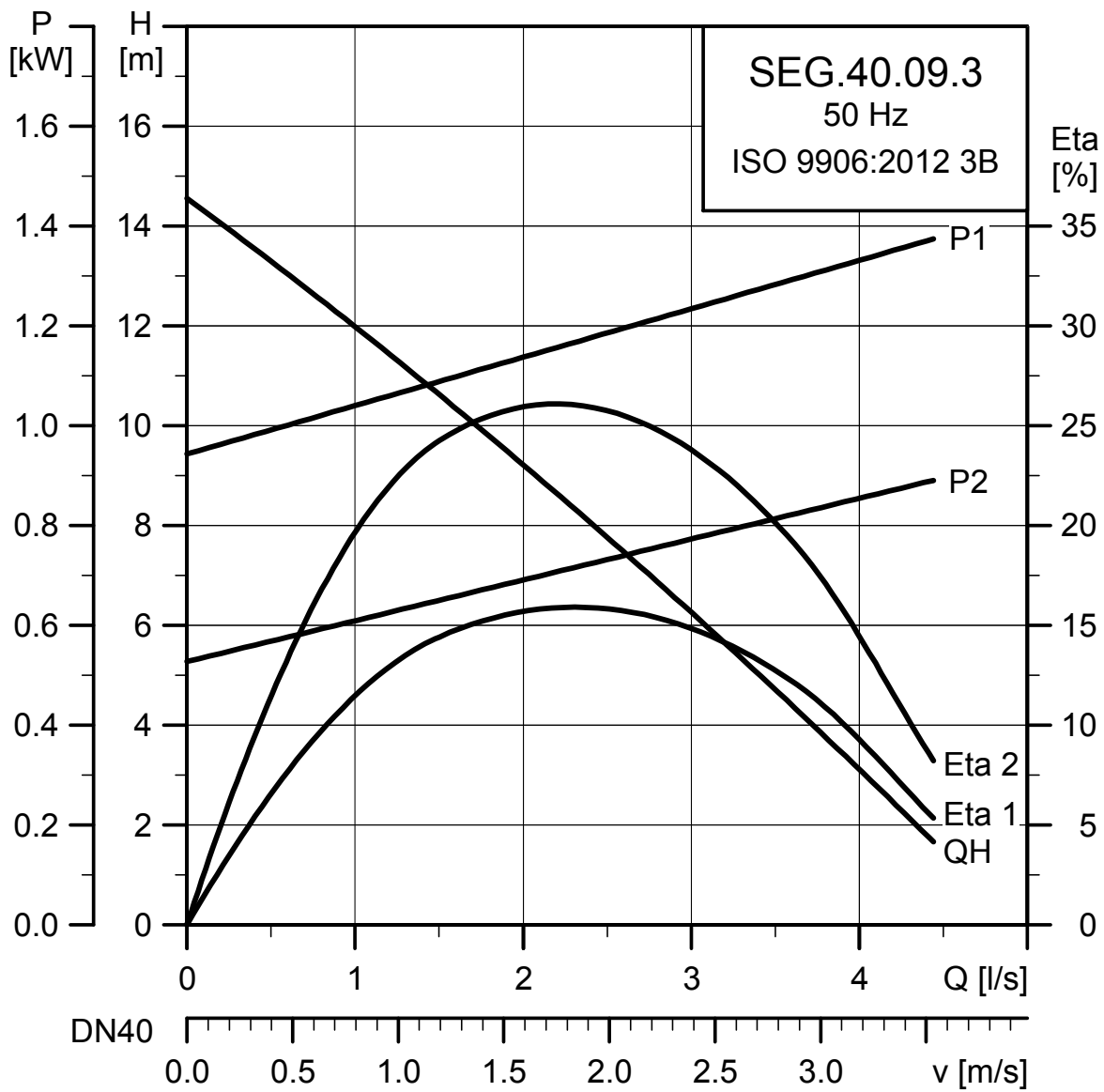

TM025269

Electrical data

Voltage [V]	P1 [kW]	P2 [kW]	Number of poles	min ⁻¹	Starting method	I _N		η _{motor} [%]			Cos φ			Moment of inertia [kgm ²]	Breakdown torque M _{max} [Nm]
						[A]	[A]	1/2	3/4	1/1	1/2	3/4	1/1		
1 x 230-240	1.4	0.9	2	2860	DOL	4.5	36	60	67	71	0.5	0.62	0.72	0.0036	12
3 x 400-415	1.4	0.9	2	2860	DOL	2.6	21	60	67	71	0.5	0.62	0.72	0.0036	12

Pump data

Impeller type	Maximum solids size	Maximum number of starts per hour	Maximum installation depth	Enclosure class	Insulation class	Maximum liquid temperature	pH	Ex class
	[mm]		[m]			[°C]		
Semi-open	Grinder system	30	10	IP68	F	40	4-14	EEX d IIB T4 Class I Zone II

10.1.3 SEG.40.12.(E).(Ex).2.1.502

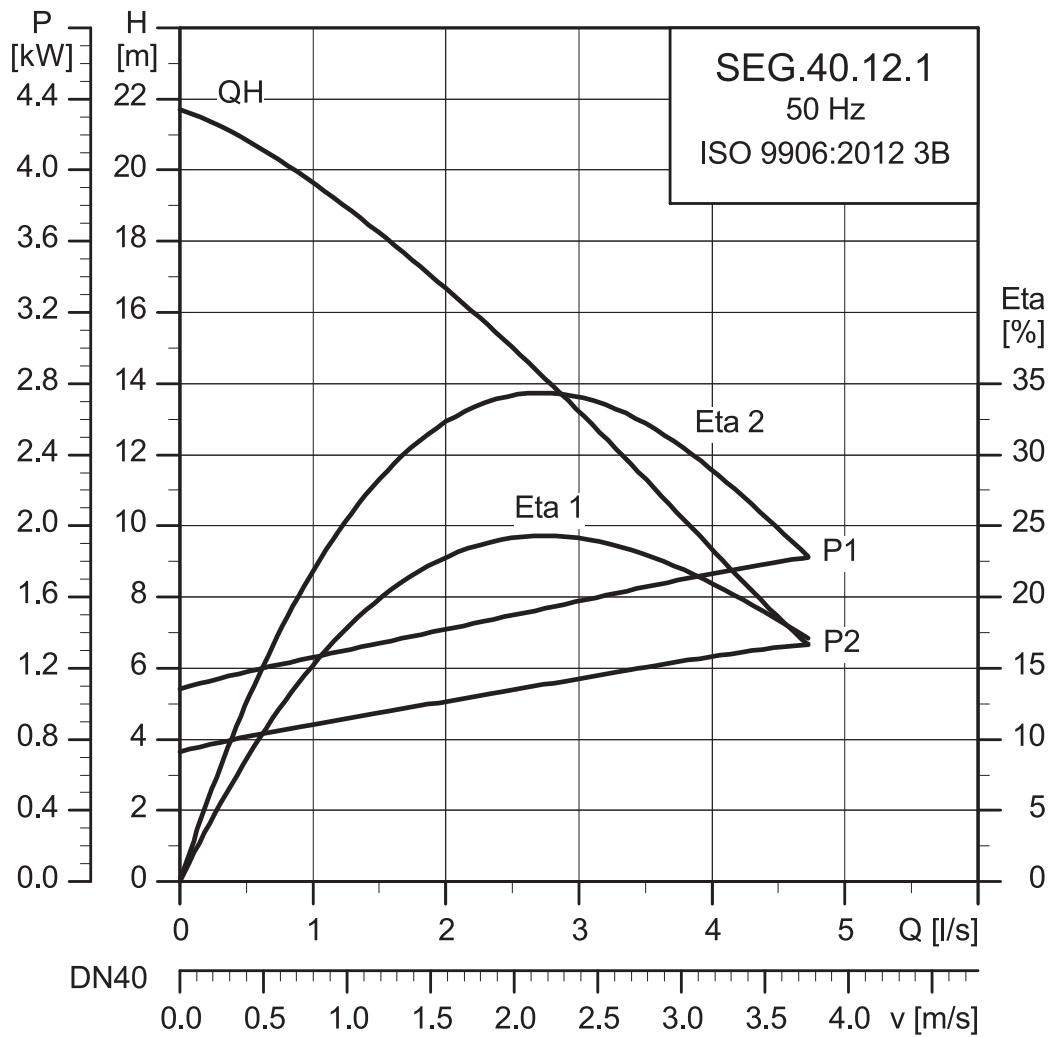

TM025268

Electrical data

Voltage [V]	P1 [kW]	P2 [kW]	Number of poles	min ⁻¹	Starting method	I _N		η _{motor} [%]			Cos φ			Moment of inertia [kgm ²]	Breakdown torque M _{max} [Nm]
						[A]	[A]	1/2	3/4	1/1	1/2	3/4	1/1		
1 x 230	1.8	1.2	2	2820	DOL	8.2	38	65	71	73	0.97	0.99	0.99	0.0038	7

Pump data

Impeller type	Maximum solids size	Maximum number of starts per hour	Maximum installation depth	Enclosure class	Insulation class	Maximum liquid temperature	pH	Ex class
	[mm]		[m]			[°C]		
Semi-open	Grinder system	30	10	IP68	F	40	4-14	EEX d IIB T4 Class I Zone II

10.1.4 SEG.40.12.(E).(Ex).2.50B/C

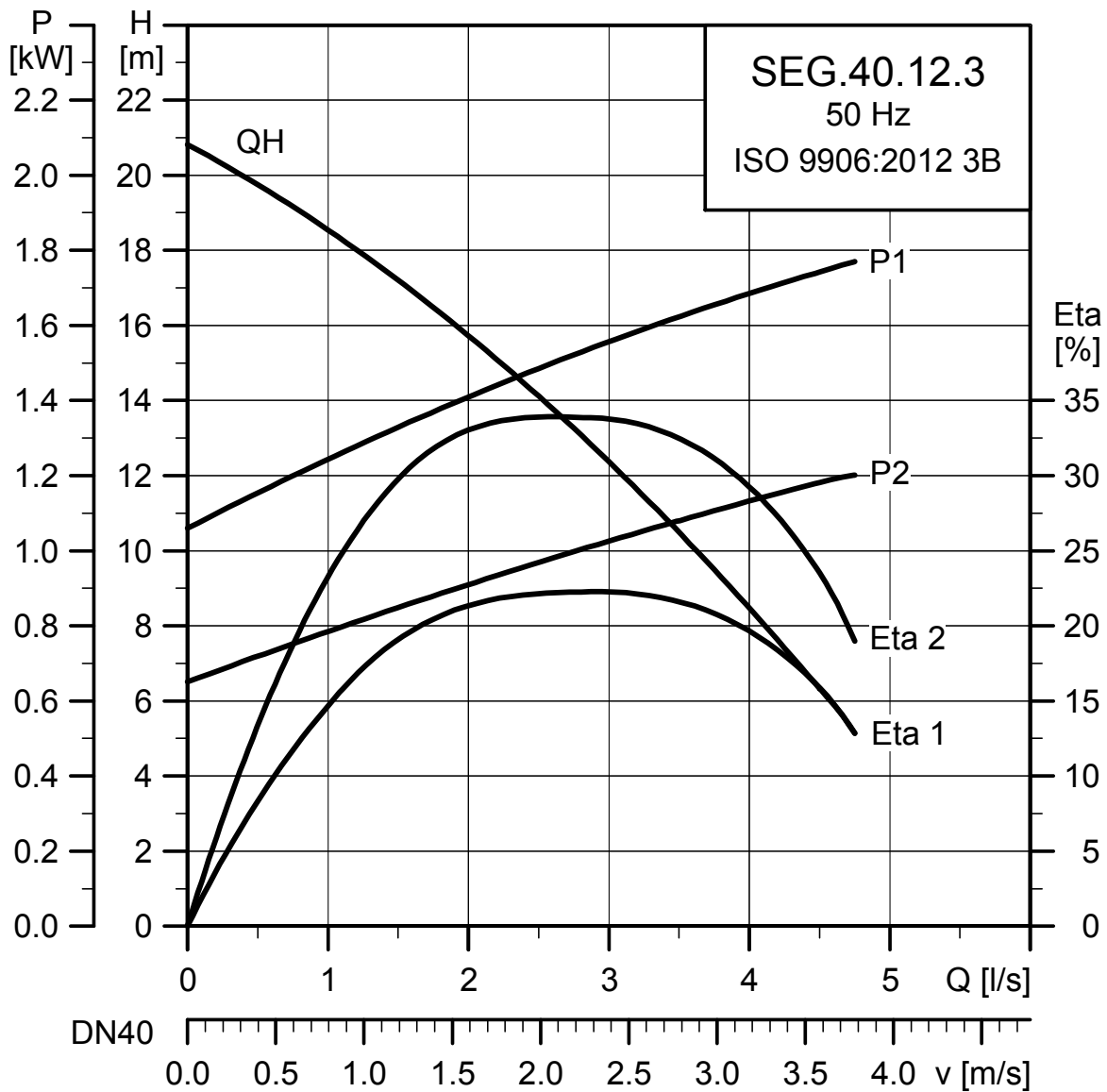

TM025267

Electrical data

Voltage [V]	P1 [kW]	P2 [kW]	Number of poles	min ⁻¹	Starting method	I _N			I _{start}			η _{motor} [%]			Cos φ			Moment of inertia [kgm ²]	Breakdown tor- que M _{max.} [Nm]
						[A]	[A]	[A]	1/2	3/4	1/1	1/2	3/4	1/1	1/2	3/4	1/1		
3 x 230-240	1.8	1.2	2	2750	DOL	5.4	36	66	71	73	0.58	0.73	0.81	0.0038	12				
3 x 400-415	1.8	1.2	2	2750	DOL	3.1	21	66	71	73	0.58	0.73	0.81	0.0038	12				

Pump data

Impeller type	Maximum solids size	Maximum number of starts per hour	Maximum installation depth	Enclosure class	Insulation class	Maximum liquid temperature	pH	Ex class
	[mm]		[m]			[°C]		
Semi-open	Grinder system	30	10	IP68	F	40	4-14	EEX d IIB T4 Class I Zone II

10.1.5 SEG.40.15.(E).(Ex).2.1.502

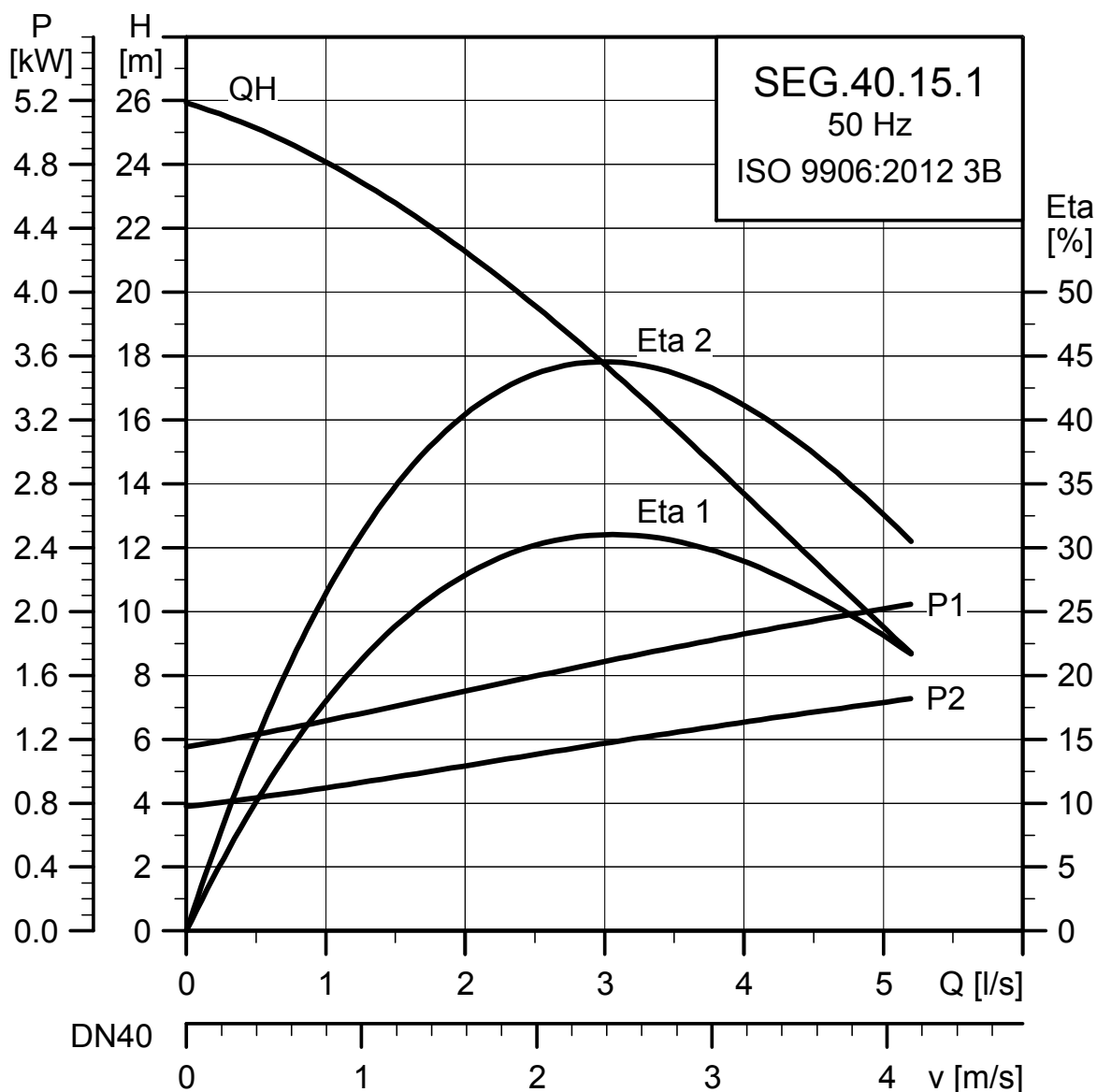

TM058030

Electrical data

Voltage [V]	P1 [kW]	P2 [kW]	Number of poles	min ⁻¹	Starting method	I _N			I _{start}			η _{motor} [%]			Cos φ			Moment of inertia [kgm ²]	Breakdown torque M _{max.} [Nm]
						[A]	[A]	[A]	1/2	3/4	1/1	1/2	3/4	1/1	1/2	3/4	1/1		
1 x 230	2.1	1.5	2	2780	DOL	7.0	38		0.64	0.72	0.72	0.721	0.789	0.821	0.008	7			

Pump data

Impeller type	Maximum solids size [mm]	Maximum number of starts per hour	Maximum installation depth [m]	Enclosure class	Insulation class	Maximum liquid temperature		pH	Ex class
						[°C]			
Semi-open	Grinder system	30	10	IP68	F	40		4-14	EEX d IIB T4 Class I Zone II

10.1.6 SEG.40.15.(E).(Ex).2.50B/C

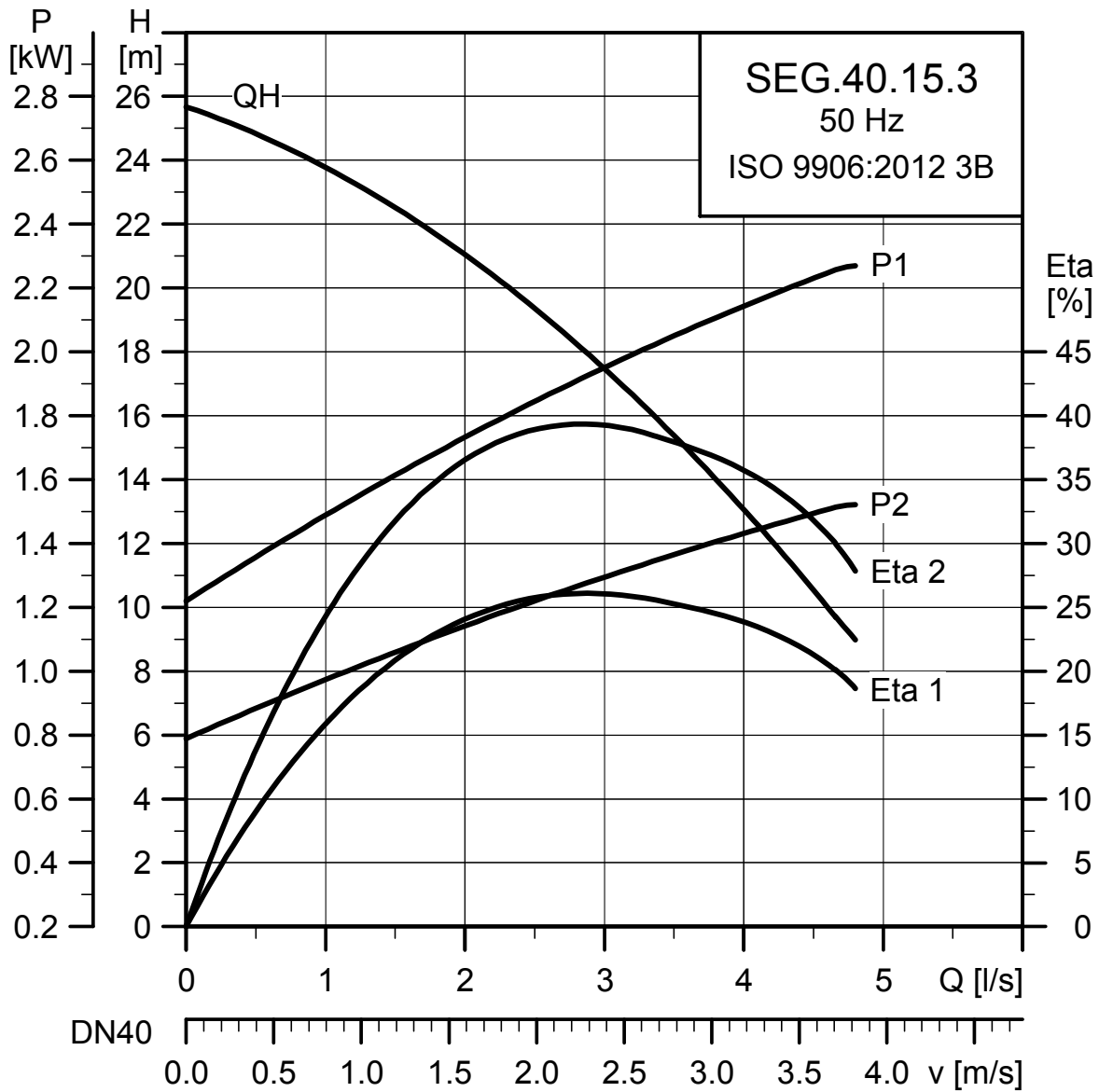

TM025266

Electrical data

Voltage [V]	P1 [kW]	P2 [kW]	Number of poles	min ⁻¹	Starting method	I _N			I _{start}			η _{motor} [%]			Cos φ			Moment of inertia [kgm ²]	Breakdown tor- que M _{max} . [Nm]
						[A]	[A]	[A]	1/2	3/4	1/1	1/2	3/4	1/1	1/2	3/4	1/1		
3 x 230-240	2.3	1.5	2	2700	DOL	6.6	36	69	71	72	0.66	0.79	0.87	0.004	12				
3 x 400-415	2.3	1.5	2	2750	DOL	3.8	21	69	73	72	0.66	0.79	0.87	0.004	12				

Pump data

Impeller type	Maximum solids size	Maximum number of starts per hour	Maximum installation depth	Enclosure class	Insulation class	Maximum liquid temperature	pH	Ex class
	[mm]		[m]			[°C]		
Semi-open	Grinder system	30	10	IP68	F	40	4-14	EEX d IIB T4 Class I Zone II

10.1.7 SEG.40.26.(E).(Ex).2.50B/C

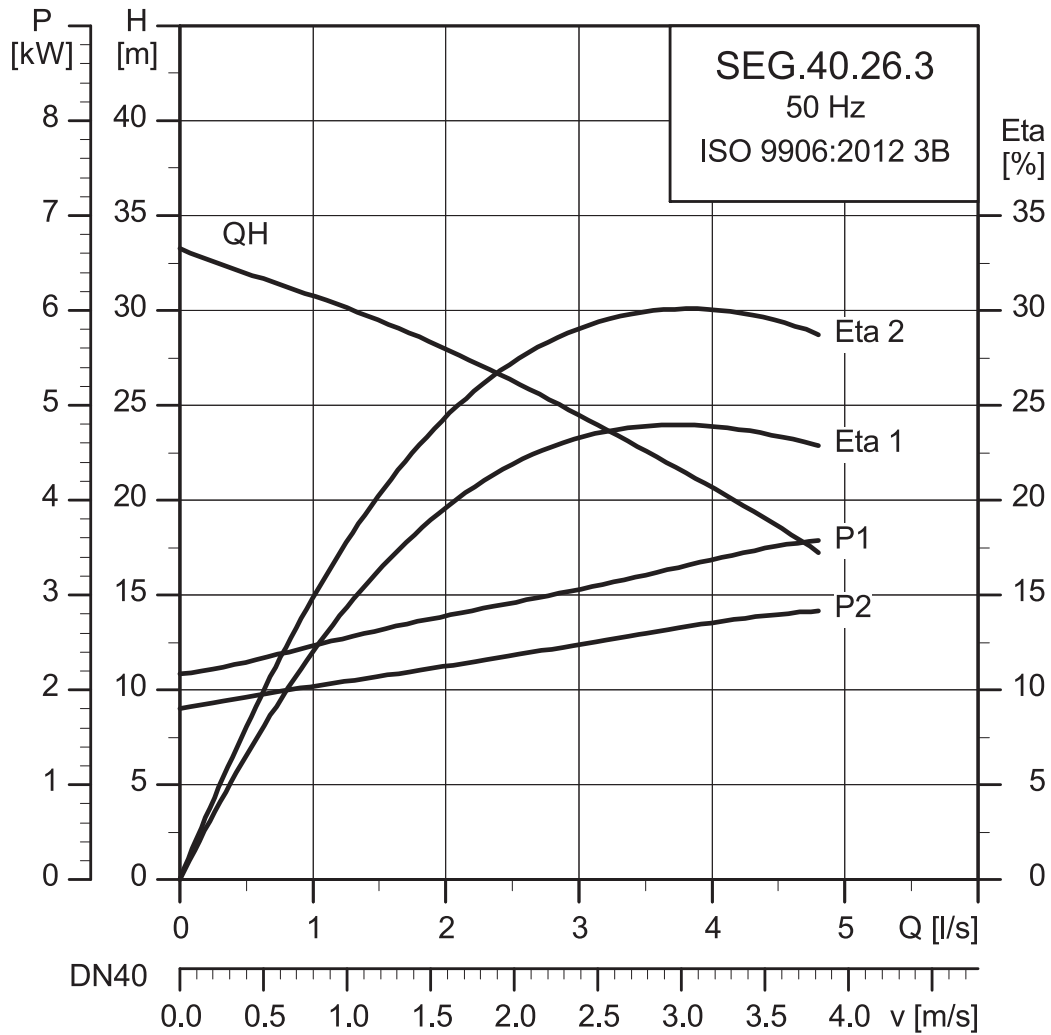

TM025271

Electrical data

Voltage [V]	P1 [kW]	P2 [kW]	Number of poles	min ⁻¹	Starting method	I _N			I _{start}			η _{motor} [%]			Cos φ			Moment of inertia [kgm ²]	Breakdown torque M _{max} [Nm]
						[A]	[A]	[A]	1/2	3/4	1/1	1/2	3/4	1/1	1/2	3/4	1/1		
3 x 230-240	3.7	2.6	2	2870	DOL	10.6	57	84	84	82	0.68	0.81	0.87	0.0093	24				
3 x 400-415	3.7	2.6	2	2870	DOL	6.1	33	84	84	82	0.68	0.81	0.87	0.0093	24				

Pump data

Impeller type	Maximum solids size	Maximum number of starts per hour	Maximum installation depth	Enclosure class	Insulation class	Maximum liquid temperature	pH	Ex class
	[mm]		[m]			[°C]		
Semi-open	Grinder system	30	10	IP68	F	40	4-14	EEX d IIB T4 Class I Zone II

10.1.8 SEG.40.31.(E).(Ex).2.50B/C

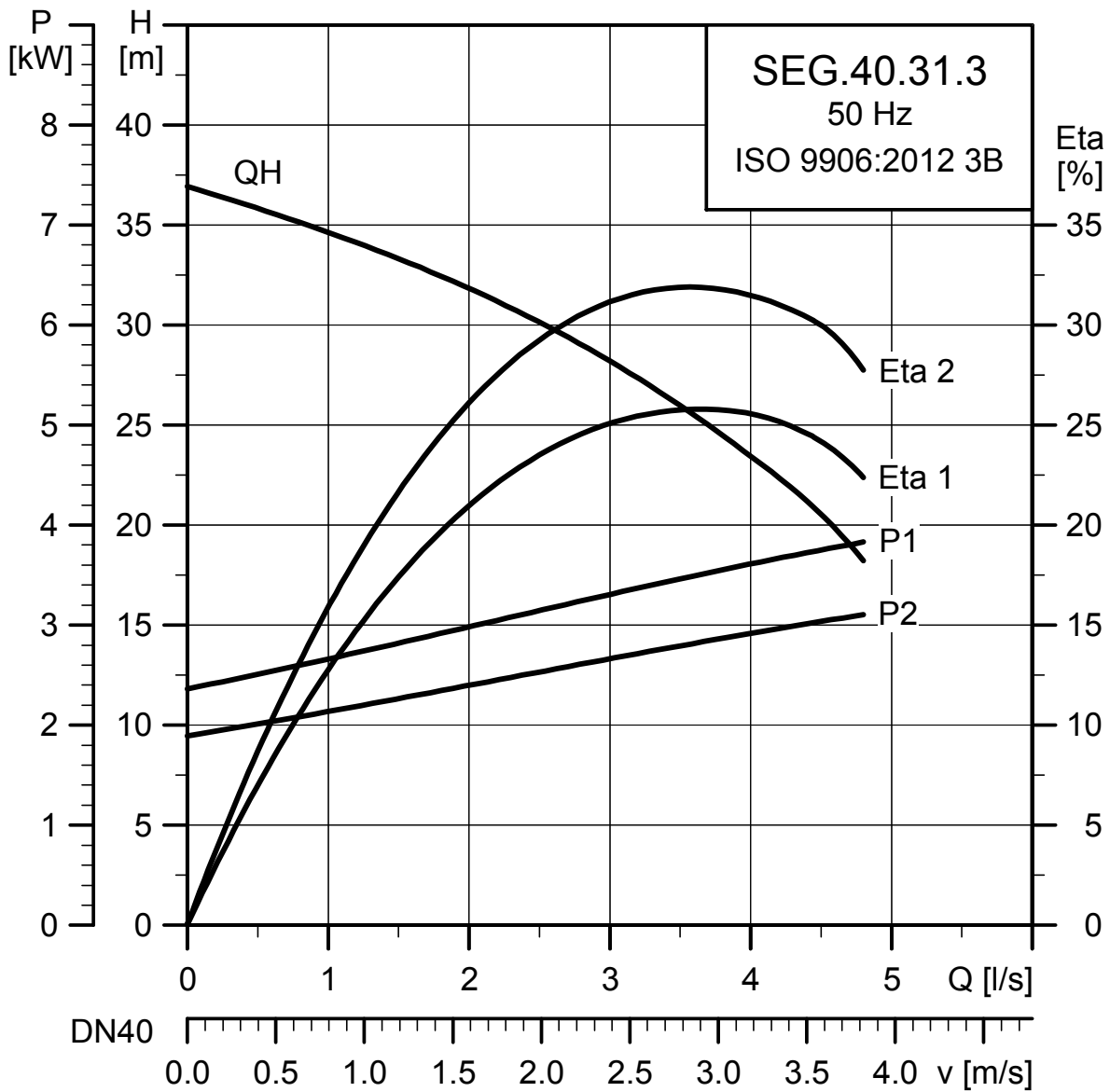

TM025272

Electrical data

Voltage [V]	P1 [kW]	P2 [kW]	Number of poles	min ⁻¹	Starting method	I _N		η _{motor} [%]			Cos φ			Moment of inertia [kgm ²]	Breakdown tor- que M _{max.} [Nm]
						I _{start} [A]	I _N [A]	1/2	3/4	1/1	1/2	3/4	1/1		
3 x 230-240	3.9	3.1	2	2900	DOL	10.9	74	79	82	84	0.71	0.81	0.86	0.01	33
3 x 400-415	3.9	3.1	2	2900	DOL	6.3	43	79	82	84	0.71	0.81	0.86	0.01	33

Pump data

Impeller type	Maximum solids size	Maximum number of starts per hour	Maximum installation depth	Enclosure class	Insulation class	Maximum liquid temperature	pH	Ex class
	[mm]		[m]			[°C]		
Semi-open	Grinder system	30	10	IP68	F	40	4-14	EEX d IIB T4 Class I Zone II

10.1.9 SEG.40.40.(E).(Ex).2.50B/C

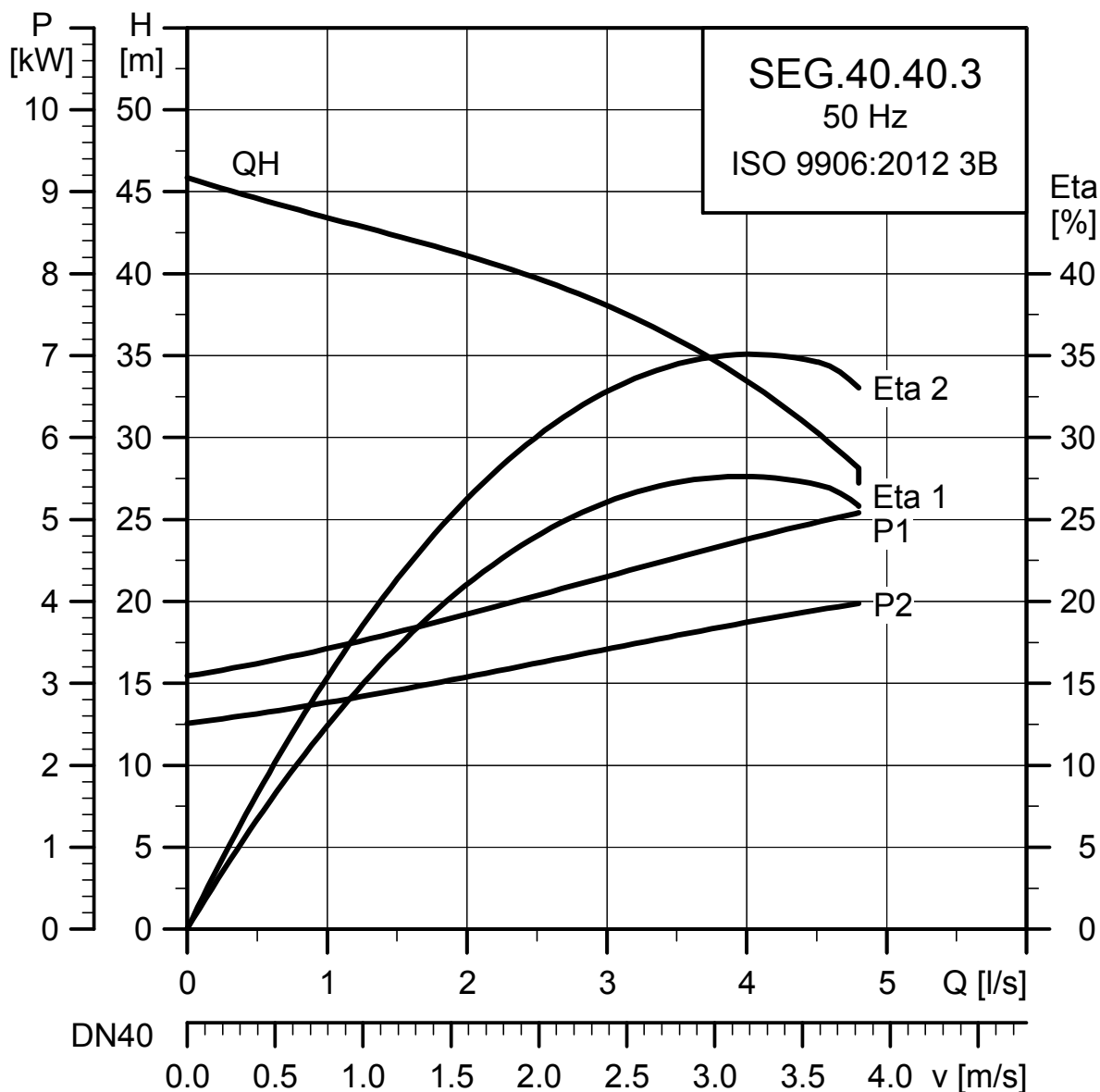

TM025273

Electrical data

Voltage [V]	P1 [kW]	P2 [kW]	Number of poles	min ⁻¹	Starting method	I _N			I _{start}			η _{motor} [%]			Cos φ			Moment of inertia [kgm ²]	Breakdown tor- que M _{max.} [Nm]
						[A]	[A]	[A]	[A]	[A]	[A]	[A]	1/2	3/4	1/1	1/2	3/4		
3 x 230-240	5.2	4.0	2	2830	DOL	14.2	74	80	82	82	0.81	0.89	0.92	0.011	33				
3 x 400-415	5.2	4.0	2	2830	DOL	8.2	43	80	82	82	0.81	0.89	0.92	0.011	33				

Pump data

Impeller type	Maximum solids size	Maximum number of starts per hour	Maximum installation depth	Enclosure class	Insulation class	Maximum liquid temperature	pH	Ex class
	[mm]		[m]			[°C]		
Semi-open	Grinder system	30	10	IP68	F	40	4-14	EEX d IIB T4 Class I Zone II

10.2 SEG.50

10.2.1 SEG.50.26.(E).(Ex).2.50B/C

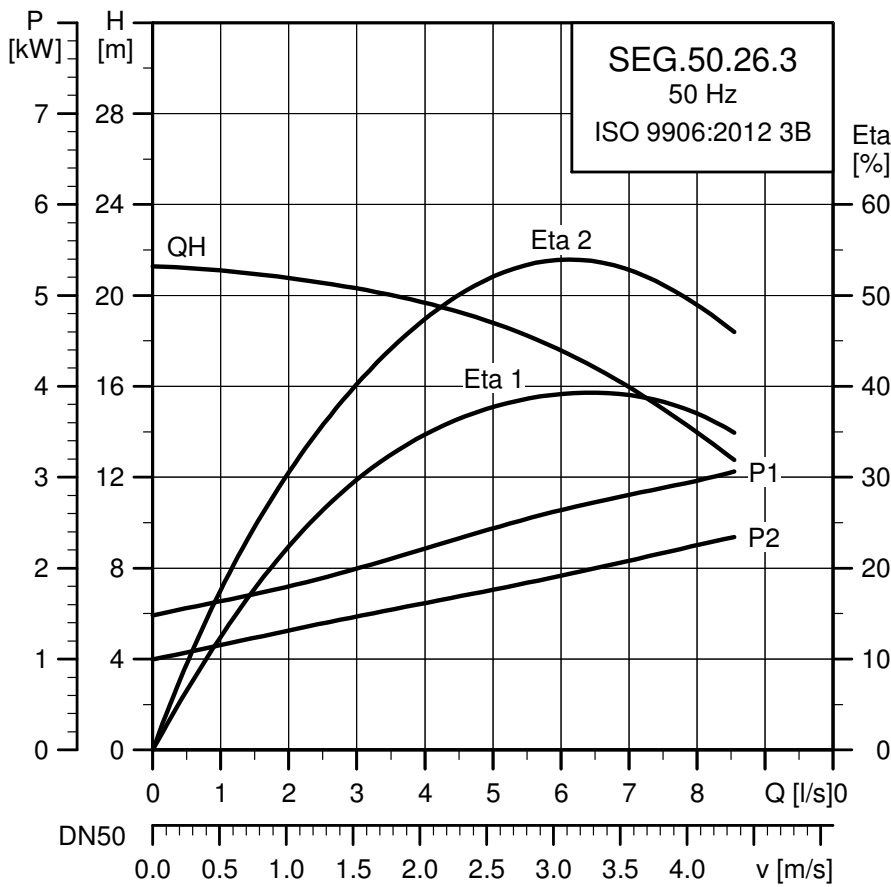

TM070114

Electrical data

Pos.	Description
1	TM07 0114 4217

Electrical data

Voltage [V]	P1 [kW]	P2 [kW]	Number of poles	min ⁻¹	Starting method	I _N			I _{start}			η _{motor} [%]			Cos φ			Moment of inertia [kgm ²]	Breakdown tor- que M _{max} . [Nm]
						[A]	[A]	[A]	1/2	3/4	1/1	1/2	3/4	1/1	1/2	3/4	1/1		
3 x 400-415	3.2	2.6	2	2870	DOL	6	33	0.84	0.84	0.84	0.68	0.81	0.87	0.0072	24				
3 x 230-240	3.2	2.6	2	2870	DOL	10	57	0.84	0.84	0.82	0.68	0.81	0.87	0.0072	24				

Pump data

Impeller type	Maximum solids size	Maximum number of starts per hour	Maximum installation depth	Enclosure class	Insulation class	Maximum liquid temperature	pH	Ex class
	[mm]					[°C]		
Semi-open	Grinder system	30	10	IP68	F	40	4-14	EEX d IIB T4 Class I Zone II

10.2.2 SEG.50.31.(E).(Ex).2.50B/C

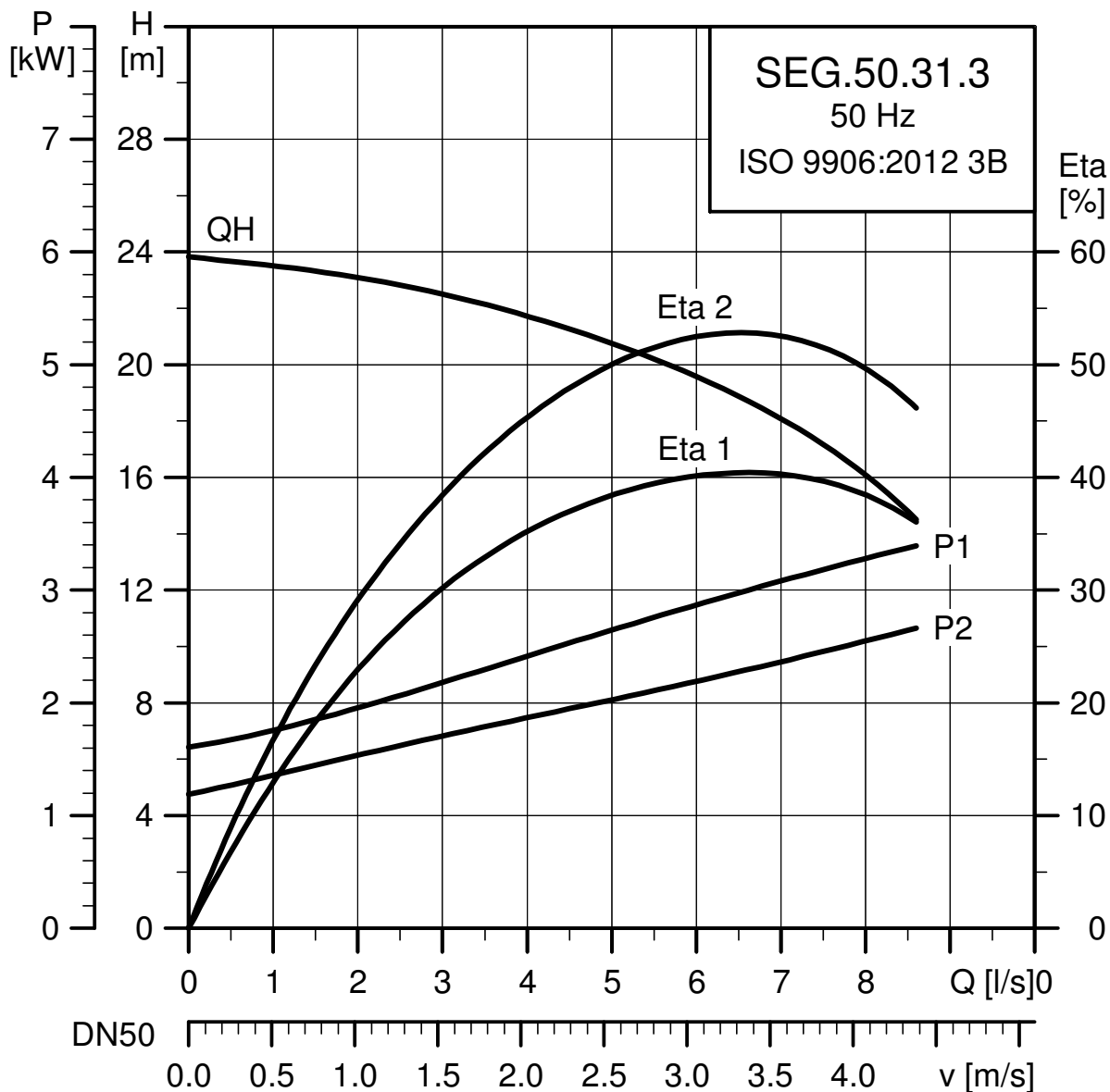

TM070115

Electrical data

Pos.	Description
1	TM07 0115 4217

Electrical data

Voltage [V]	P1 [kW]	P2 [kW]	Number of poles	min ⁻¹	Starting method	I _N		η _{motor} [%]			Cos φ			Moment of inertia [kgm ²]	Breakdown torque M _{max} [Nm]
						[A]	[A]	1/2	3/4	1/1	1/2	3/4	1/1		
3 x 400-415	3.7	3.1	2	2900	DOL	7	43	0.79	0.82	0.84	0.71	0.81	0.86	0.0075	33
3 x 230-240	3.7	3.1	2	2900	DOL	11	74	0.79	0.82	0.84	0.71	0.81	0.86	0.0075	33

Pump data

Impeller type	Maximum solids size	Maximum number of starts per hour	Maximum installation depth	Enclosure class	Insulation class	Maximum liquid temperature	pH	Ex class
	[mm]		[m]			[°C]		
Semi-open	Grinder system	30	10	IP68	F	40	4-14	EEX d IIB T4 Class I Zone II

10.2.3 SEG.50.40.(E).(Ex).2.50B/C

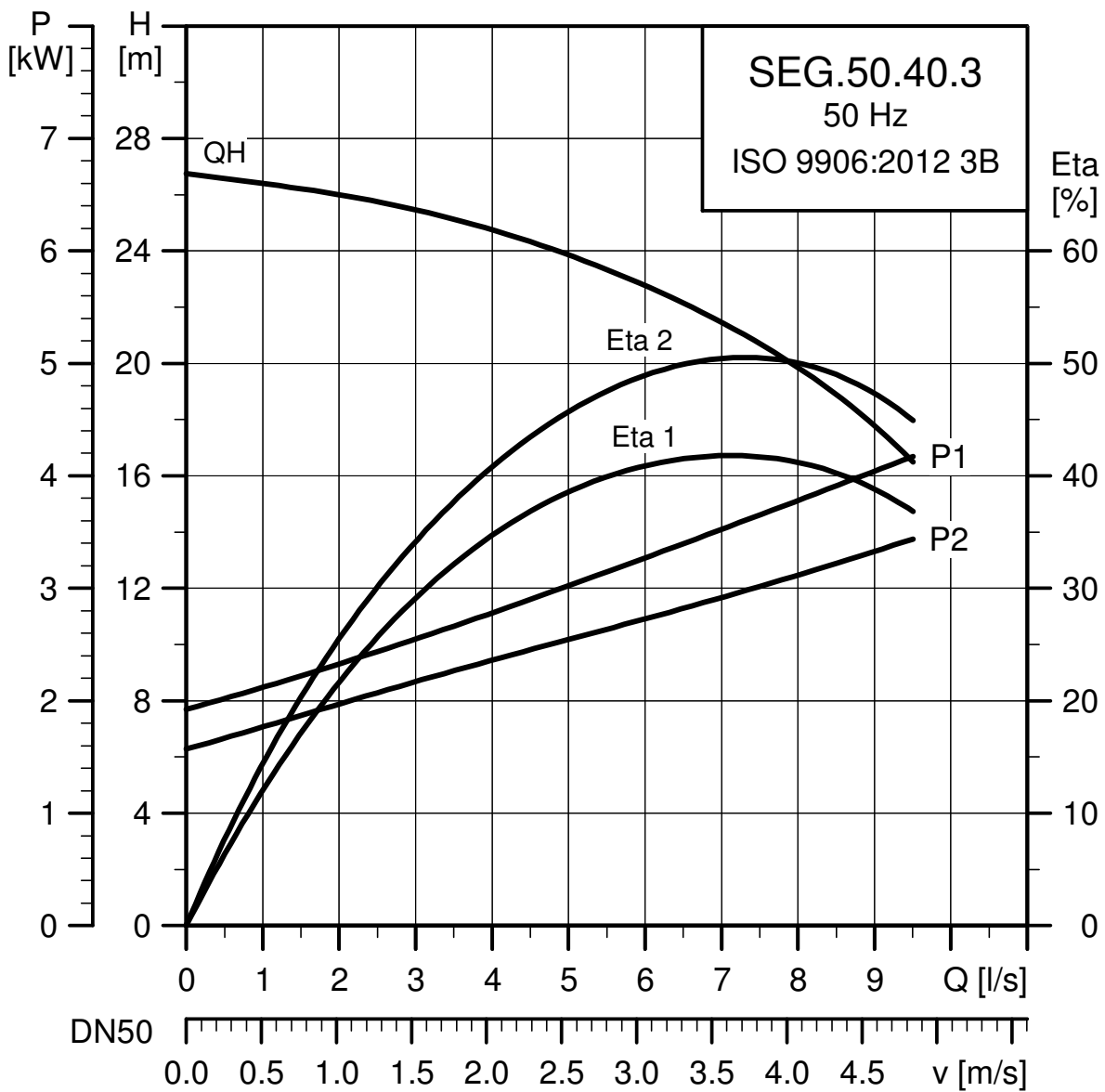

TM070116

Electrical data

Pos.	Description
1	TM07 0116 4217

Electrical data

Voltage [V]	P1 [kW]	P2 [kW]	Number of poles	min ⁻¹	Starting method	I _n		η _{motor} [%]			Cos φ			Moment of inertia [kgm ²]	Breakdown torque M _{max} [Nm]
						[A]	[A]	1/2	3/4	1/1	1/2	3/4	1/1		
3 x 400-415	4.9	4.0	2	2830	DOL	8	43	0.80	0.82	0.82	0.81	0.89	0.92	0.0085	33
3 x 230-240	4.39	4.0	2	2830	DOL	14	74	0.80	0.82	0.82	0.81	0.89	0.92	0.0085	33

Pump data

Impeller type	Maximum solids size	Maximum number of starts per hour	Maximum installation depth	Enclosure class	Insulation class	Maximum liquid temperature	pH	Ex class
	[mm]		[m]			[°C]		
Semi-open	Grinder system	30	10	IP68	F	40	4-14	EEX d IIB T4 Class I Zone II

11. Dimensions and weights

11.1 SEG

11.1.1 Hookup auto coupling and auto coupling installation

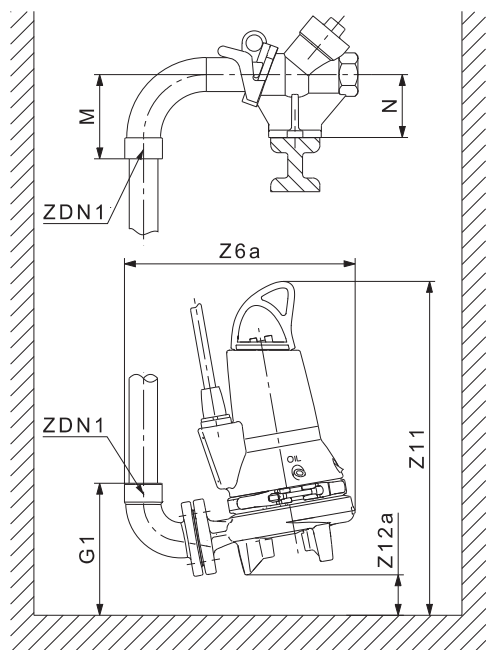

TM06 5744 0116

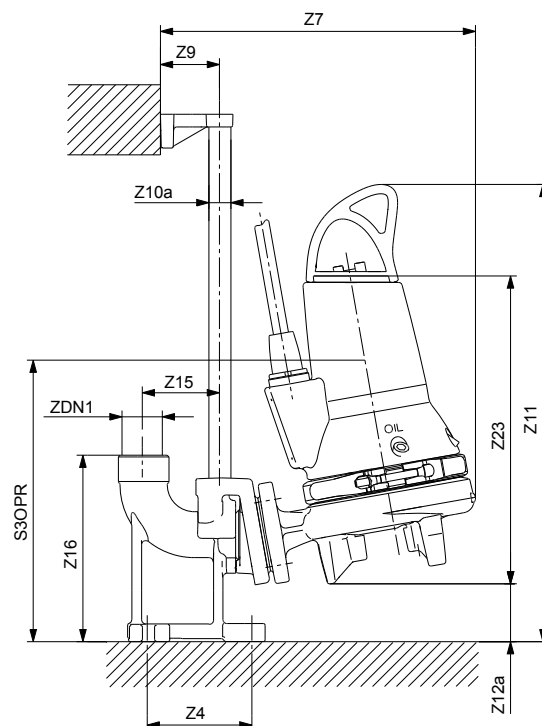

TM06 5743 0116

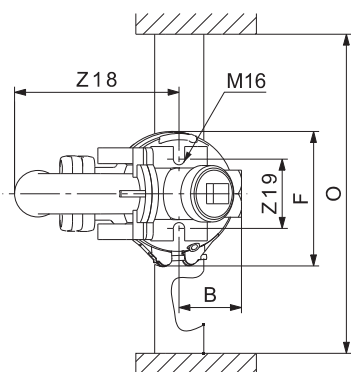

TM065744

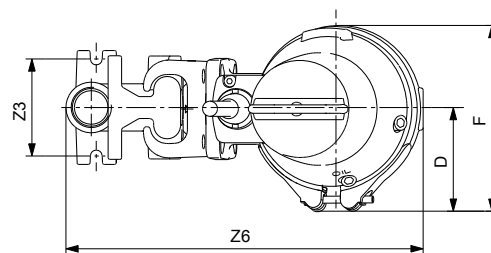

TM065743

Installation on hookup auto coupling

Installation on auto coupling

SEG.40

Power [kW]	B	D	F	ZDN1	G1	M	N	O	Z3	Z4	Z6	Z6a
0.9 and 1.2	100	99	216	Rp 1 1/2	214	134	100		115	118	424	365
1.5 (1-phase)	100	99	216	Rp 1 1/2	214	134	100		115	118	424	365
1.5 (3-phase)	100	99	216	Rp 1 1/2	214	134	100	Min. 600	115	118	424	365
2.6	100	119	256	Rp 1 1/2	214	134	100		115	118	460	365
3.1 and 4.0	100	119	256	Rp 1 1/2	214	134	100		115	118	460	365

Power [kW]	Z7	Z9	Z10a	Z11	Z12a	Z15	Z16	Z18	Z19	Z23	S3OPR
0.9 and 1.2	374	70	3/4" - 1"	546	68	90	221	271	120	363	346
1.5 (1-phase)	374	70	3/4" - 1"	551	68	90	221	271	120	363	361
1.5 (3-phase)	374	70	3/4" - 1"	546	68	90	221	271	120	368	346
2.6	410	70	-	614	80	90	221	271	120	349	371
3.1 and 4.0	410	70	-	652	80	90	221	271	120	432	371

SEG.50

Power [kW]	B	D	F	ZDN1	G1	M	N	O	Z3	Z4	Z6	Z6a
2.6	100	119	256	Rp 2"	215	134	100	Min. 600	95	179	460	365
3.1 and 4.0	100	119	256	Rp 2"	215	134	100		95	179	460	365

Power [kW]	Z7	Z9	Z10a	Z11	Z12a	Z15	Z16	Z18	Z19	Z23	S3OPR
2.6	410	70	3/4" - 1"	646	67	90	226	271	120	442	371
3.1 and 4.0	410	70	3/4" - 1"	684	67	90	226	271	120	481	371

11.1.2 Free-standing installation

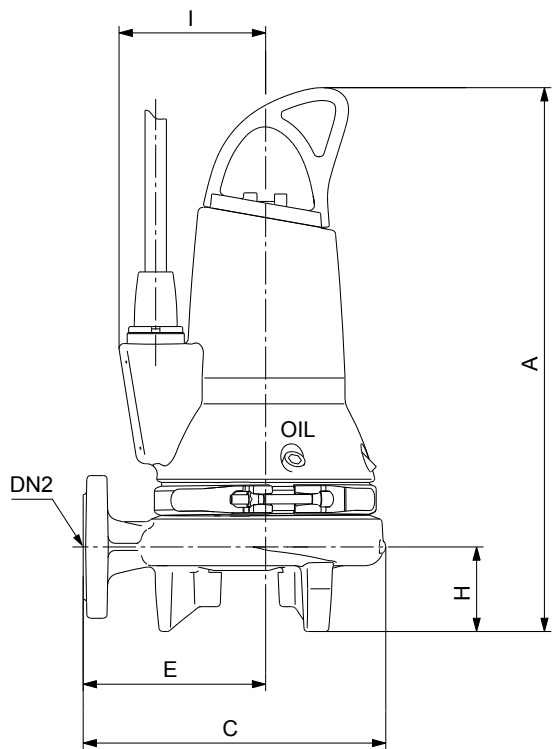

TM06 5742 47 16

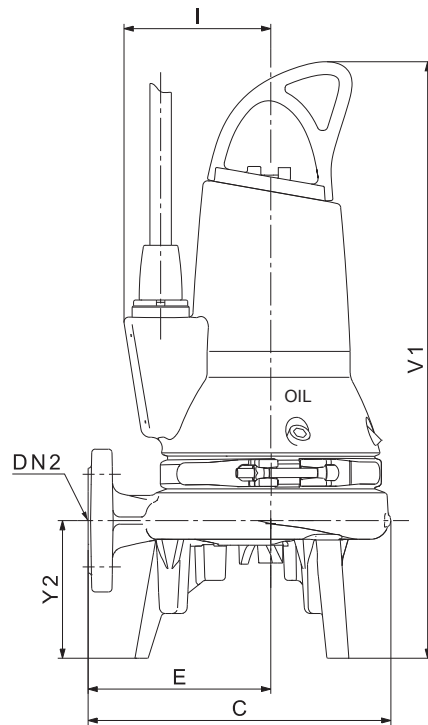

TM06 5745 01 16

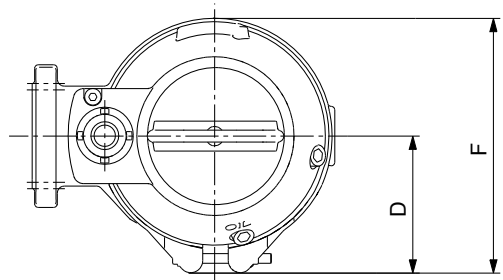

TM065742

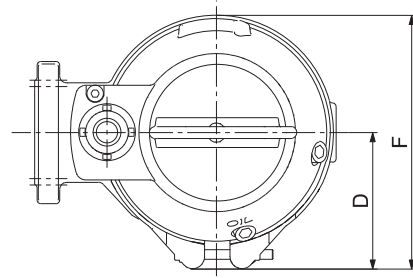

TM065745

Free-standing installation

Free-standing installation with foot extensions

SEG.40

Power [kW]	A	C	D	DN2	E	F	H	I	V1	Y2
0.9 and 1.2	466	255	99	DN 40	154	216	71	123	510	116
1.5 (1-phase)	471	255	99	DN 40	154	216	71	123	515	116
1.5 (3-phase)	466	255	99	DN 40	154	216	71	123	510	116
2.6	522	292	119	DN 40	173	256	60	143	582	115
3.1 and 4.0	562	292	119	DN 40	173	256	60	144	622	115

SEG.50

Power [kW]	A	C	D	DN2	E	F	H	I	V1	Y2
2.6	554	294	119	50	173	256	73	143	614	115
3.1 and 4.0	594	294	119	50	173	256	73	143	654	115

11.1.2.1 Weights

Pump type	Weight [kg]
SEG.40.09...	38.0
SEG.40.12...	38.0
SEG.40.15.(EX).2.1.502	30.0

SEG.40.15.(EX).2.50B/C	38.0
SEG.40.26...	57.0
SEG.40.31...	65.0

SEG.40.40...	65.0
SEG.50.26...	64.0
SEG.50.31...	72.0
SEG.50.40...	72.0

11.2 SEG AUTOADAPT

11.2.1 Hookup auto coupling and auto coupling installation

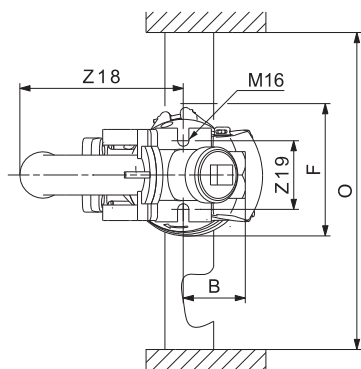
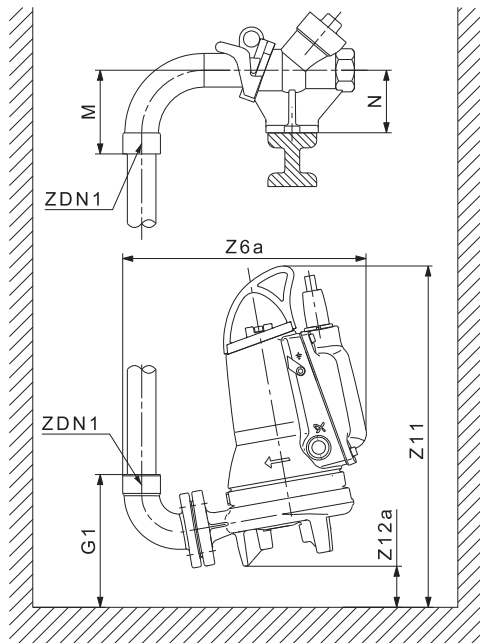

TM06 5755 0116

TM065755

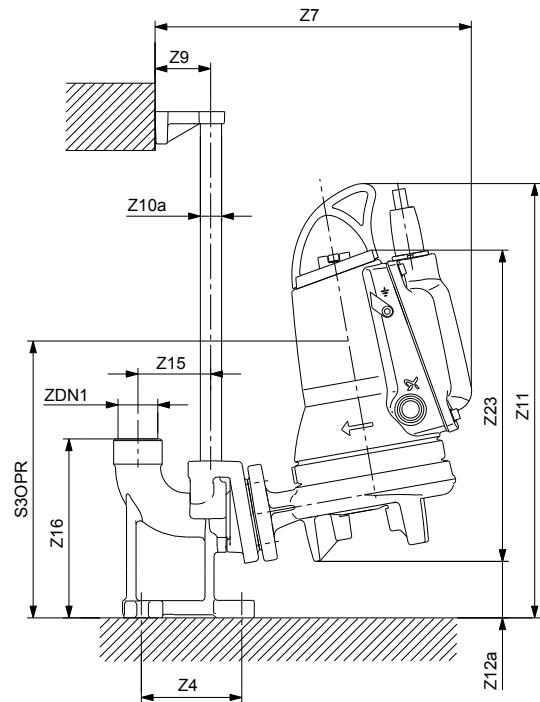

TM06 5754 0116

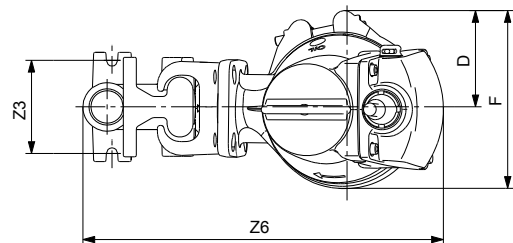

TM065754

Installation on hookup auto coupling

Installation on auto coupling

SEG.40

Power [kW]	B	D	F	ZDN1	G1	M	N	O	Z3	Z4	Z6	Z6a
0.9 and 1.2	100	99	216	Rp 1 1/2	214	134	100		115	118	495	388
1.5 (1-phase)	100	99	216	Rp 1 1/2	214	134	100		115	118	495	388
1.5 (3-phase)	100	99	216	Rp 1 1/2	214	134	100	Min. 600	115	118	495	388
2.6	100	119	256	Rp 1 1/2	215	134	100		115	118	531	423
3.1 and 4.0	100	119	256	Rp 1 1/2	215	134	100		115	118	531	423

Power [kW]	Z7	Z9	Z10a	Z11	Z12a	Z15	Z16	Z18	Z19	Z23	S3OPR
0.9 and 1.2	397	70	3/4" - 1"	536	68	90	221	271	120	363	346
1.5 (1-phase)	397	70	3/4" - 1"	551	68	90	221	271	120	363	361
1.5 (3-phase)	397	70	3/4" - 1"	536	68	90	221	271	120	368	346
2.6	433	70	3/4" - 1"	619	80	90	221	271	120	349	371
3.1 and 4.0	433	70	3/4" - 1"	657	80	90	221	271	120	432	371

SEG.50

Power [kW]	B	D	F	ZDN1	G1	M	N	O	Z3	Z4	Z6	Z6a
2.6	100	119	256	Rp 1 1/2	215	134	100	Min. 600	115	118	531	423
3.1 and 4.0	100	119	256	Rp 1 1/2	214	134	100		115	118	531	423

Power [kW]	Z7	Z9	Z10a	Z11	Z12a	Z15	Z16	Z18	Z19	Z23	S3OPR
2.6	433	70	3/4" - 1"	634	67	90	221	271	120	435	371
3.1 and 4.0	433	70	3/4" - 1"	672	67	90	221	271	120	475	371

11.2.2 Free-standing installation

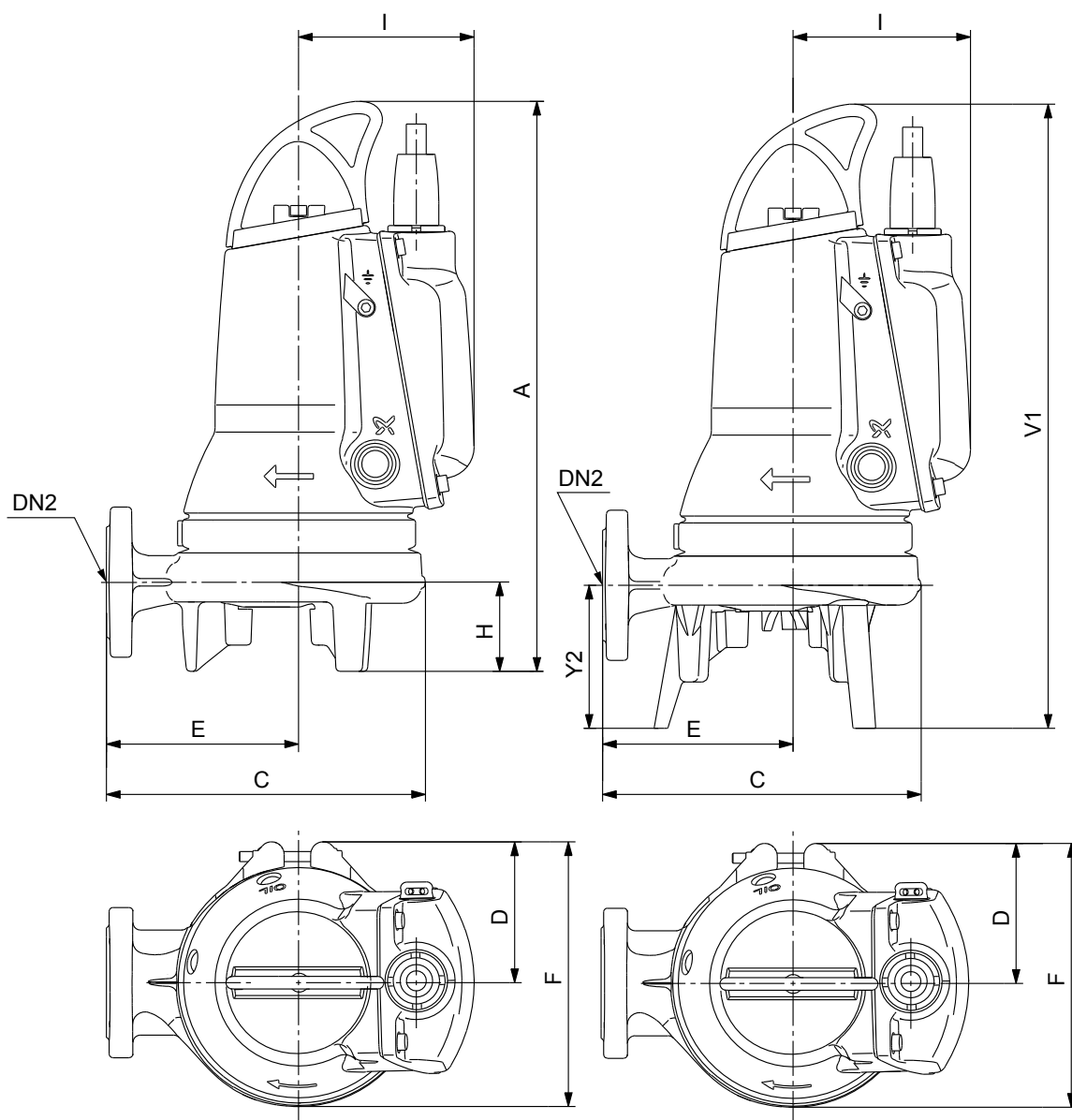

TM065753

Free-standing installation with or without foot extensions

SEG.40

Power [kW]	A	C	D	DN2	E	F	H	I	V1	Y2
0.9 and 1.2	456	255	99	DN 40	154	216	71	140	500	116
1.5 (1-phase)	471	255	99	DN 40	154	216	71	140	515	116
1.5 (3-phase)	456	255	99	DN 40	154	216	71	140	500	116
2.6	527	292	119	DN 40	173	256	60	166	582	115
3.1 and 4.0	567	292	119	DN 40	173	256	60	166	622	115

SEG.50





Power [kW]	A	C	D	DN2	E	F	H	I	V1	Y2
2.6	575	292	119	50	173	256	60	166	597	115
3.1 and 4.0	615	292	119	50	173	256	60	166	637	115

11.2.3 Weights

Pump type	Weight [kg]
SEG.40.09.E...	38.0
SEG.40.12.E...	38.0
SEG.40.15.E.(EX).2.1.502	50.0
SEG.40.15.(EX).2.50B	38.0
SEG.40.26.E...	57.0
SEG.40.31.E...	65.0
SEG.40.40.E...	65.0
SEG.50.26...	64.0
SEG.50.31...	72.0
SEG.50.40...	72.0

12. Accessories



12.1 Installation accessories for SEG and SEG AUTO_{ADAPT} pumps

No	Product	Description	Dimensions	Product number	SEG.40		SEG.50	
					Standard	AUTO _{ADAPT}	Standard	AUTO _{ADAPT}
1		Auto-coupling system complete, i.e. upper guide rail bracket, bolts, nuts, gaskets, guide claw and base stand. Cast iron. Note: In installations with guide rails longer than 4 metres, we recommend that you use intermediate guide rail bracket.	DN 40 / Rp 1 1/2	96076063	•	•		
			DIN DN 50 pit / PS	97695874	•	•	•	•
			JIS/KS DN 50 pit / PS	98245794	•	•	•	•
2		Hookup auto coupling, i.e. base stand, counterpart, bolts, nuts and gaskets. Cast iron.	DN 40 / Rp 1 1/2	96076089	•	•		
			DN 40 / Rp 1 1/2	97713859	•	•		
3		Three loose feet extensions to be fitted to the pump housing of free-standing pumps.	-	96076196	•	•	•	•
4		Guide rail bracket. Guide rails of 4 m and longer.	DN 40 / DN 50	96887609	•	•	•	•

12.2 Other accessories

No	Product	Description	Dimensions	Product number	
1		Lifting chain with shackle. With certificates. Stainless steel, EN 1.4571/A4. Up to 500 kg.	2 m		98538174
			3 m		98538175
			4 m		98538176
			6 m		98538177
			8 m		98538178
			10 m		98538179
			2 m		98425759
			4 m		98425760
			6 m		98425781
			8 m		98425782
			10 m		98425783
			2 m		98425796
			4 m		98425797
			6 m		98425798
			8 m		98425799
10 m		98425800			

No	Product	Description	Version	Product number	SEG.40		SEG.50	
					Standard	AUTO _{ADAPT}	Standard	AUTO _{ADAPT}
2		Groundfos power-line PC Tool Link USB communication unit.	All AUTO _{ADAPT} pumps	97655366		•		•
3		For Grundfos GO Remote: MI 202 iPhone dongle complete with IR and radio communication.	Apple iPod touch 4 iPhone 4G	98046376		•		•
		For Grundfos GO Remote: MI 204 iPhone dongle complete with IR and radio communication.	Apple iPod touch 5 iPhone 5	98424092		•		•
4		For Grundfos GO Remote: MI301 module with built-in IR and radio communication. Use the module together with an Android or iOS-based smartphone with Bluetooth connection.	-	98046408		•		•
		GENIbus communication * Grundfos GO Remote	CIU 902	97644690		•		•
		Profibus communication Profibus DP + Grundfos GO Remote	CIU 152	98128063		•		•
5		Modbus RTU + Grundfos GO Remote	CIU 202	97644728		•		•
		GSM / GPRS / SMS For communication with a SCADA or similar system + Grundfos GO Remote	CIU 252	98347271		•		•

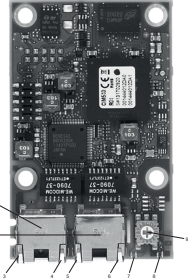
No	Product	Description	Version	Product number	SEG.40		SEG.50	
					Standard	AUTO _{ADAPT}	Standard	AUTO _{ADAPT}
		Grundfos Remote Management (GRM) + Grundfos GO Remote	CIU 272	97644730		•		•
		PROFIBUS IO + Grundfos GO Remote MODBUS TCP + Grundfos GO Remote	CIU 902 +	97644690 +		•		•
5		BACNET IP + Grundfos GO Remote GRM IP + Grundfos GO Remote	CIM 500	98301408				
		Communication by means of radio communication	CIU 902 +	97644690 +		•		•
		CIU 902 with CIM 060 wireless complete.	CIM 060	98778356				
		AUTO _{ADAPT} fuse box, 1 pump without space for CIU	-	98491143		•		•
		AUTO _{ADAPT} fuse box, 1 pump with space for CIU	-	98491149		•		•
		AUTO _{ADAPT} fuse box, 2 pumps without space for CIU	-	98491153		•		•
		AUTO _{ADAPT} fuse box, 2 pumps with space for CIU	-	98491155		•		•
		Option: AUTO _{ADAPT} CIU 202 Modbus RTU **	-	98492189		•		•
		Option: AUTO _{ADAPT} CIU 272 GRM **	-	98492205		•		•
		Option: AUTO _{ADAPT} CIU 902 **	-	98492206		•		•
		Option: AUTO _{ADAPT} CIU 252 GSM complete **	-	98492207		•		•
		Option: AUTO _{ADAPT} service plug 230 V *, 50 Hz **	-	98492208		•		•
		Option: AUTO _{ADAPT} plug for PC Tool Link Box **	-	98492209		•		•
		Option: AUTO _{ADAPT} fault light mounted on top **	-	98492212		•		•
		Option: AUTO _{ADAPT} audio alarm, 80 dB **	-	98492214		•		•

* The modules are supplied as two parts which must be built together.

** Accessories for control box must be ordered together.

12.3 SEG pumps

Level controllers

Grundfos offers a wide range of pump controllers controlling the liquid levels in the wastewater collecting pit, ensuring correct operation and protection of the pumps.

Controller ranges:

- Dedicated Controls control cabinets
- LC and LCD level controllers
- CU 100 control unit.

LC and CU 100 are designed for one-pump installations, and Dedicated Controls and LCD are designed for two-pump installations.

Dedicated Controls

The Grundfos Dedicated Controls system controls and monitors up to six Grundfos wastewater pumps and a mixer or a flush valve.

The Dedicated Controls systems are used in installations requiring advanced control and data communication.

Main components of the Dedicated Controls system:

- CU 362 control unit
- IO 351B module (general I/O module).

The Dedicated Controls systems are available either as separate components or as control cabinets, i.e. dedicated controls.

The control system can be operated by the following:

- float switches
- a level sensor
- an analog pressure transmitter or ultrasonic level transmitter
- a level sensor and safety float switches.

The control cabinet is available for the following pump sizes and starting methods:

- pumps up to and including 9 kW, direct-on-line starting
- pumps up to and including 30 kW, variable frequency drives
- pumps up to and including 30 kW, star-delta starting
- pumps up to and including 30 kW, soft starter.

The separate control unit and modules can be built for practically any size of system.



TM060918

Dedicated Controls control cabinet

The Dedicated Controls cabinets can be fitted with various units:

- The CU 362 control unit, which is the "brain" of the Dedicated Controls system, is fitted in the cabinet front. CU 362 can be fitted with one of the Grundfos CIM communication modules mentioned below, depending on the monitoring requirements or the SCADA system:
 - CIM 202: The communication module is used for the Modbus RTU fieldbus protocol.
 - CIM 252: The communication module is used for GSM/GPRS communication. CIM 252 establishes communication between CU 362 and a SCADA system, thereby allowing the application to be monitored and controlled remotely. This module also offers SMS messaging, for example status and alarm messages.
 - CIM 272: The communication module is used for the Grundfos Remote Management system (GRM). CIM 272 establishes communication between CU 362 and GRM, thereby allowing the application to be monitored and controlled remotely.
 - CIM 060: The communication module enables Dedicated Controls to work with Grundfos GO Remote.
 - CIM 150: The communication module is used for the PROFIBUS DP protocol.

- CIM 500: The communication module is an industrial Ethernet high-speed module for PROFINET and Modbus TCP communication.
- IO 351B: The general I/O module communicates with CU 362 via GENibus.
- IO/SM 113: The pump sensor interface is used for WIO and PT sensors.
- MP 204: The motor protector (optional) provides many electrical status values, such as voltage, current, power, insulation resistance and energy. MP 204 offers better protection of the pumps than a conventional motor protection device.
- The CUE/VFD (optional), which is either a Grundfos variable-frequency converter or a general variable-frequency converter, also offers better pump protection and a more steady flow through the pipes. As a result, the pumps are not overloaded, and the energy consumption is kept at a minimum.

For further information, see the data booklet or installation and operating instructions for Dedicated Controls in Grundfos Product Center at www.grundfos.com.

LC and LCD

The Grundfos LC and LCD range of level controllers comprise three series with a total of six variants:

- LC and LCD 107 operated by air bells
- LC and LCD 108 operated by float switches
- LC and LCD 110 operated by electrodes
- LC and LCD 115 operated by level transmitters.

All controllers are ideally suited for applications requiring up to 11 kW motors for direct-on-line starting. LC and LCD can also be supplied with an integrated star-delta starter for applications requiring larger motors up to and including 30 kW.

Features and benefits

- Control of one pump (LC) or two pumps (LCD)
- automatic alternating operation of two pumps (LCD)
- automatic test run, preventing shaft seals from seizing up in the event of long periods of inactivity
- water hammer protection
- starting delay after power supply failure
- automatic alarm resetting, if required
- automatic restarting, if required
- alarm outputs as NO and NC.



TM042360

LCD 110 for two-pump installations

When an SMS module (optional) is fitted in an LC or LCD controller, it acts as a time recorder for the pumps. When programmed, using an ordinary mobile phone with text messaging facility, the SMS module can send text messages containing "high-level alarm", "general alarm", information about operation and the number of times the pump has started. The SMS module is also available with battery which allows it to send text messages informing you of power failure and restorage of the power.

For further information, see the data booklet or installation and operating instructions for the LC and LCD controllers in Grundfos Product Center at www.grundfos.com.

CU 100

The CU 100 control unit is designed for the starting, operation and protection of small wastewater pumps.

The control unit is available in several variants suitable for the following:

- single-phase pumps, up to and including 9 A
- three-phase pumps, up to and including 5 A
- start/stop by means of a float switch
- manual start/stop.

During manual operation, the pump is started and stopped by means of the on/off switch.

During automatic operation, the float switch starts and stops the pump.

For further information, see the installation and operating instructions for CU 100 in Grundfos Product Center at www.grundfos.com.



CU 100

TM026459

12.4 SEG AUTOADAPT pumps**12.4.1 Grundfos CIU**

The Grundfos communication interface unit (CIU) is used as a communication interface between a Grundfos product and a main network for the following functions:

- configuration of pump parameters required for water level control
- online monitoring of pit and pump values
- manual water level control (forced start/stop)
- obtaining measured and logged data that is valuable for pump service and pit optimisation.

CIU is designed for use together with Grundfos SEG AUTO_{ADAPT} pumps. Communication can be established by means of Grundfos GO Remote or by using the main CIU network interface.

Available CIU versions:

- CIU 902 without CIM module
- CIU 152 PROFIBUS DP unit
- CIU 202 Modbus unit
- CIU 252 GSM/GPRS unit
- CIU 272 GRM unit (Grundfos Remote Management).

CIU incorporates one or two modules:

- multi-purpose IO module with I/O functionality, IR communication interface and powerline communication
- CIM 2XX (optional).

For further information about the CIM module fitted, see the installation and operating instructions for the relevant CIM module.

If a CIM module is fitted in CIU, the sensors connected to the digital input of the IO module can be remotely monitored from a centrally located SCADA system.

Grundfos GO Remote

Grundfos GO Remote is designed for wireless IR communication with Grundfos products.

Grundfos GO Remote can communicate with the SEG AUTO_{ADAPT} pumps via a CIU unit.

Grundfos GO Remote is an ordinary service and measuring tool and is therefore designed to withstand wear and stress from everyday use.

If you use a CIU 902, you can mount a CIM 060 wireless module in the CIU 902, which allows you to connect to Grundfos GO Remote using wireless radio communication instead of infrared communication.

Name	DC	LC	LCD	CU 100	AUTO _{ADAPT}	CIU
Application						
One pump	•	•		•	•	•
Two pumps	•		•		•	•
Mixer	•					
Battery back-up	•					
Level sensor						
Float switches	•	•	•	•		• 7)
Electrodes		•	•			• 7)
Air bells		•	•			• 7)
Pressure sensor	•				• 3)	• 7)
Ultrasonic sensor	•					• 7)
Analog level sensor with safety float switches	•					• 7)
Starting method						
Direct-on-line starting	•	•	•	•	•	•
Star-delta starting	•	•	•			
Soft starter	•					
Basic functions						
Start and stop of pump(s)	•	•	•	•	•	•
Pump alternation			•		•	•
High-level alarm	•	•	•		•	•
Dry-running alarm	•	•	•		•	•
Flow measurement, calculated or via flow sensor	•					
Pump statistics	•				• 4)	•
Conflicting levels alarm	•					
Advanced functions						
Start and stop delays	•	•	•		•	•
Motor temperature sensor	•	•	•		• 4)	•
Test run/antiseizing	•	•	•		•	•
Daily emptying of the pit	•					•
Water-in-oil sensor input	•					
Communication						
SMS messaging	• 2)	• 1)	• 1)			• 2)
SCADA communication (GSM/GPRS)	• 2)					• 5)
User interface						
Level indication	•	•	•			• 6)
Graphical display	•					• 6)
PC Tool WW Controls	•				•	

1) If an SMS module is fitted.

2) If a CIM 252 GSM/GPRS module is fitted in the CU 362.

3) Built-in pressure sensor and dry-running sensor.

4) Built-in, but a Grundfos unit is required to get access to data or setting of parameters.

5) Modbus, GSM, GPRS, SMS and GRM options.

6) When using a Grundfos GO.

7) Inputs for external sensors (NO or NC).

13. Grundfos Product Center

Online search and sizing tool to help you make the right choice.

From the international view, you can select your specific country to view the product range available to you.

International view: <https://product-selection.grundfos.com>

All the information you need in one place

Performance curves, technical specifications, pictures, dimensional drawings, motor curves, wiring diagrams, spare parts, service kits, 3D drawings, documents, system parts. The Product Center displays any recent and saved items - including complete projects - right on the main page.

Downloads

On the product pages, you can download installation and operating instructions, data booklets, service instructions, etc., in PDF format.



When you select your country, you will see the menus below. Note that some menus may not be available depending on the country.

Example: <https://product-selection.grundfos.com/uk>

Pos.	Description
1	Products & services enables you to find products and documents by typing a product number or name into the search field.
2	Applications enables you to choose an application to see how Grundfos can help you design and optimise your system.
3	Products A-Z enables you to look through a list of all the Grundfos products.
4	Categories enables you to look for a product category.
5	Liquids enables you to find pumps designed for aggressive, flammable or other special liquids.
6	Product replacement enables you to find a suitable replacement.
7	WWW enables you to select the country, which changes the language, the available product range and the structure of the website.
8	Sizing enables you to size a product based on your application and operating conditions.

