

AP40-70, AP80-100

0.7-2.6 kW, 50 Hz DIN



1. Introduction	3
Applications	3
Design features	3
2. Identification	4
Nameplate	4
Type key	4
3. Product selection	5
Ordering a pump	5
Custom-built variants	5
Accessories	5
Monitoring units and controllers	5
4. Performance ranges	6
5. Product range	8
6. Variants	9
List of variants	9
7. Design	10
Exploded views	10
8. Product description	24
Features	24
Operating conditions	25
Operating modes	25
Pump controllers	26
Frequency converter operation	26
Wiring diagrams	27
9. Performance curves	29
How to read the curve charts	29
Performance curve conditions	29
Calculation of total head	29
Performance tests	29
Certificates	29
Witness test	29
10. Performance curves and technical data	30
AP40	30
AP50	33
AP50.50	36
AP60	39
AP70	41
AP80	43
AP100	49
11. Dimensions and weights	50
12. Accessories	52
13. Grundfos Product Center	53

1. Introduction

This databooklet describes the Grundfos AP range of submersible wastewater pumps.

These pumps have vortex and single-channel (1-channel) impeller options to make them suitable for pumping wastewater in a wide range of municipal, private and industrial applications. They are made of wear-resistant materials, such as cast iron and stainless steel.

The pumps are available with 0.7 to 2.6 kW motors and 40 to 100 mm nominal outlet diameters. The pump housings have either a G 2" threaded- or flange connection.

Installation types:

- vertical, submerged installation on auto-coupling
- vertical, submerged installation on ring stand.

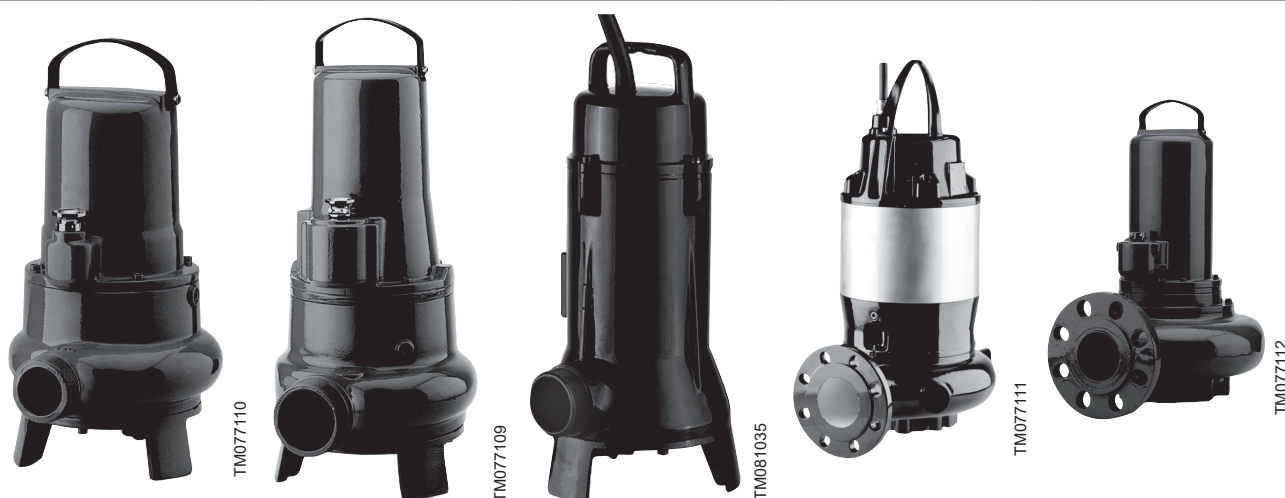

1.1 Applications

Transferred liquids:

- municipal wastewater
- wastewater with high fibre content (vortex impeller)
- drainage-and groundwater
- domestic wastewater
- industrial wastewater

Application areas:

- municipal network pumping stations
- public buildings
- blocks of flats
- factories

1.2 Design features

The following features apply to the entire pump range:

- silicon-carbide mechanical seal
- watertight cable entry
- IP68 enclosure class
- self-cleaning, 1-channel impellers with long vanes to reduce the risk of jamming or clogging
- vortex impellers with high pumping efficiency
- H-class motor insulation

2. Identification

2.1 Nameplate

Fix the extra nameplate supplied with the pump at the installation site or keep it in the cover of this booklet.

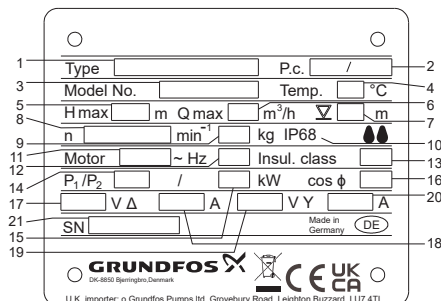

TM076788

Position	Description
1	Type designation
2	Production code, year and week
3	Product number
4	Maximum liquid temperature [°C]
5	Maximum head [m]
6	Maximum flow rate [m ³ /h]
7	Maximum installation depth [m]
8	Speed [rpm]
9	Net weight [kg]
10	Enclosure class
11	Phase
12	Frequency [Hz]
13	Insulation class
14	Motor input power P1 [kW]
15	Motor input power P2 [kW]
16	Cos φ, 1/1 load
17	Rated voltage [V], delta connection
18	Rated current [A], delta connection
19	Rated voltage [V], star connection
20	Rated current [A], star connection
21	Serial number

2.2 Type key

Fix the extra nameplate supplied with the pump at the installation site or keep it in the cover of this booklet.

Example: AP40.50.07.A.3.V

Code	Description	Explanation
AP	Wastewater/sewage pump	Pump type
40	Maximum solids size 40 = 40 mm	Pump passage
50	Nominal outlet diameter 50 = 50 mm	Pump outlet
07	Output power P2 07 = 0.7 kW	Power [kW]
A	Level switch	Control
1	Single-phase motor	Number of phases
3	Three-phase motor	
1	Single-channel impeller	Impeller type
V	Vortex impeller	
Z	Custom-built products	Customisation

3. Product selection

3.1 Ordering a pump

Prior to ordering a pump, consider the following:

- pump type
- custom-built variant
- accessories
- controller.

3.2 Custom-built variants

The pumps can be customised to meet individual requirements. Many pump features and options are available on request, such as cable lengths or special materials.

Note: Make sure to have at least 3 metres of cable above the maximum liquid level. If this is not possible with the standard cable, Grundfos offers variants with longer cables. Using cable extensions is not recommended.

3.3 Accessories

Depending on installation type and pump variant, accessories may be required.

Note: Ordered accessories are not factory-fitted.

3.4 Monitoring units and controllers

The following controllers are available:

- LC 231 - compact solution with certified motor protection
- LC 241 - cabinet solution offering modularity and customisation.

They are designed for single- or dual-pump installations. The Grundfos LC level controllers are ideal for pumps emptying and filling related to small wastewater transport, commercial buildings and tank-filling applications.

For further information, see the data booklet or installation and operating instructions on www.grundfos.com (Grundfos Product Center).

CU 100

The CU 100 control box is designed for the startup, operation and protection of small wastewater pumps. The control box is available in several variants:

- single-phase pumps (up to 9 A)
- three-phase pumps (up to 5 A).

it can be used for:

- manual operation
- automatic operation.

During manual operation, the pump is started and stopped with the on/off switch.

During automatic operation, the pump is started and stopped by a float switch.

For further information, see the installation and operating instructions for the CU 100 on www.grundfos.com (Grundfos Product Center).

4. Performance ranges

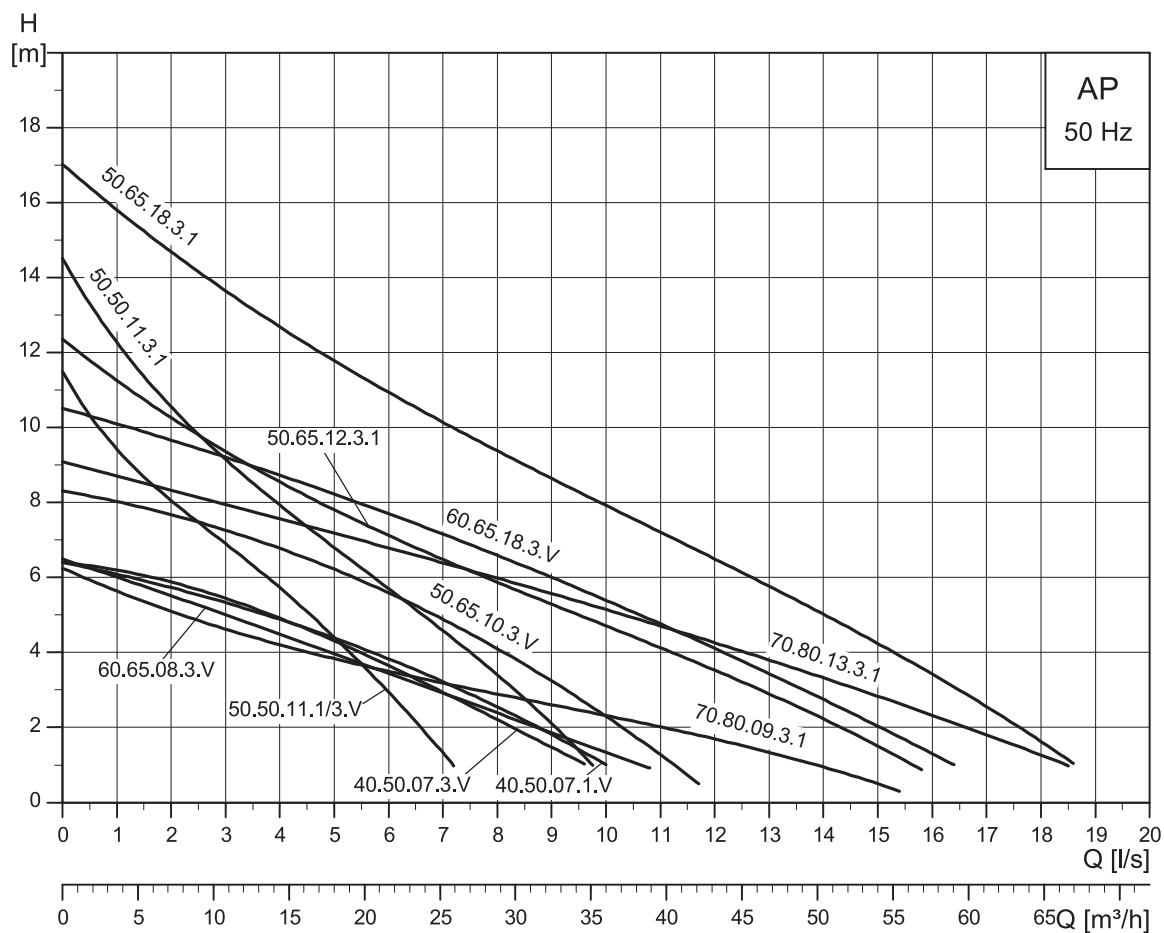

TM077237

AP40-70

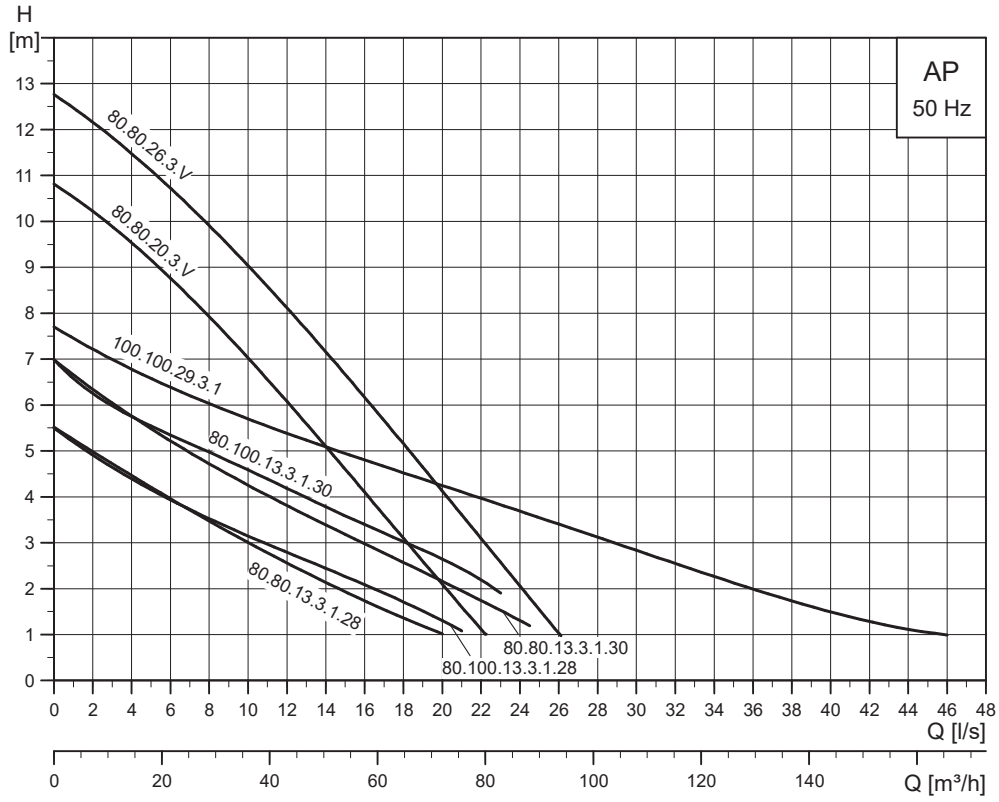

TM077238

AP80-100

5. Product range

Pump type	Product number	Phase	Voltage [V]		Starting method	Cable length [m]	Thermal protection
AP40.50.07.1.V	99895440	1	230	240	DOL	10	yes
AP40.50.07.3.V	99895442	3	400	415	DOL	10	yes
AP50.50.11.1.V	92543556	1	230	240	DOL	10	yes
AP50.50.11.A.1.V	92543557	1	230	240	DOL	10	yes
AP50.50.11.3.V	92543558	3	400	415	DOL	10	yes
AP50.50.11.3.1	92543559	3	400	415	DOL	10	yes
AP40.50.07.A.1.V	92543570	1	230	240	DOL	10	yes
AP50.65.10.3.V	99895444	3	400	415	DOL	10	yes
AP50.65.12.3.1	96002565	3	400	415	DOL	10	yes
AP50.65.18.3.1	96002567	3	400	415	DOL	10	yes
AP60.65.08.3.V	99895443	3	400	415	DOL	10	yes
AP60.65.18.3.V	99895445	3	400	415	DOL	10	yes
AP70.80.09.3.1	99895446	3	400	415	DOL	10	yes
AP70.80.13.3.1	96002592	3	400	415	DOL	10	yes
AP80.80.13.3.1.28	99895447	3	400	415	DOL	10	yes
AP80.80.13.3.1.30	99895448	3	400	415	DOL	10	yes
AP80.80.20.3.V	96005358	3	400	415	DOL	10	yes
AP80.80.26.3.V	96005359	3	400	415	DOL	10	yes
AP80.100.13.3.1.28	99895449	3	400	415	DOL	10	yes
AP80.100.13.3.1.30	99895450	3	400	415	DOL	10	yes
AP100.100.29.3.1	99895451	3	400	415	DOL	10	yes

6. Variants

6.1 List of variants

Various cable lengths	Note: Calculate a new cable cross-section when using cable lengths above 10 m.	15 m
		20 m
		25 m
		30 m

7. Design

7.1 Exploded views

7.1.1 AP40

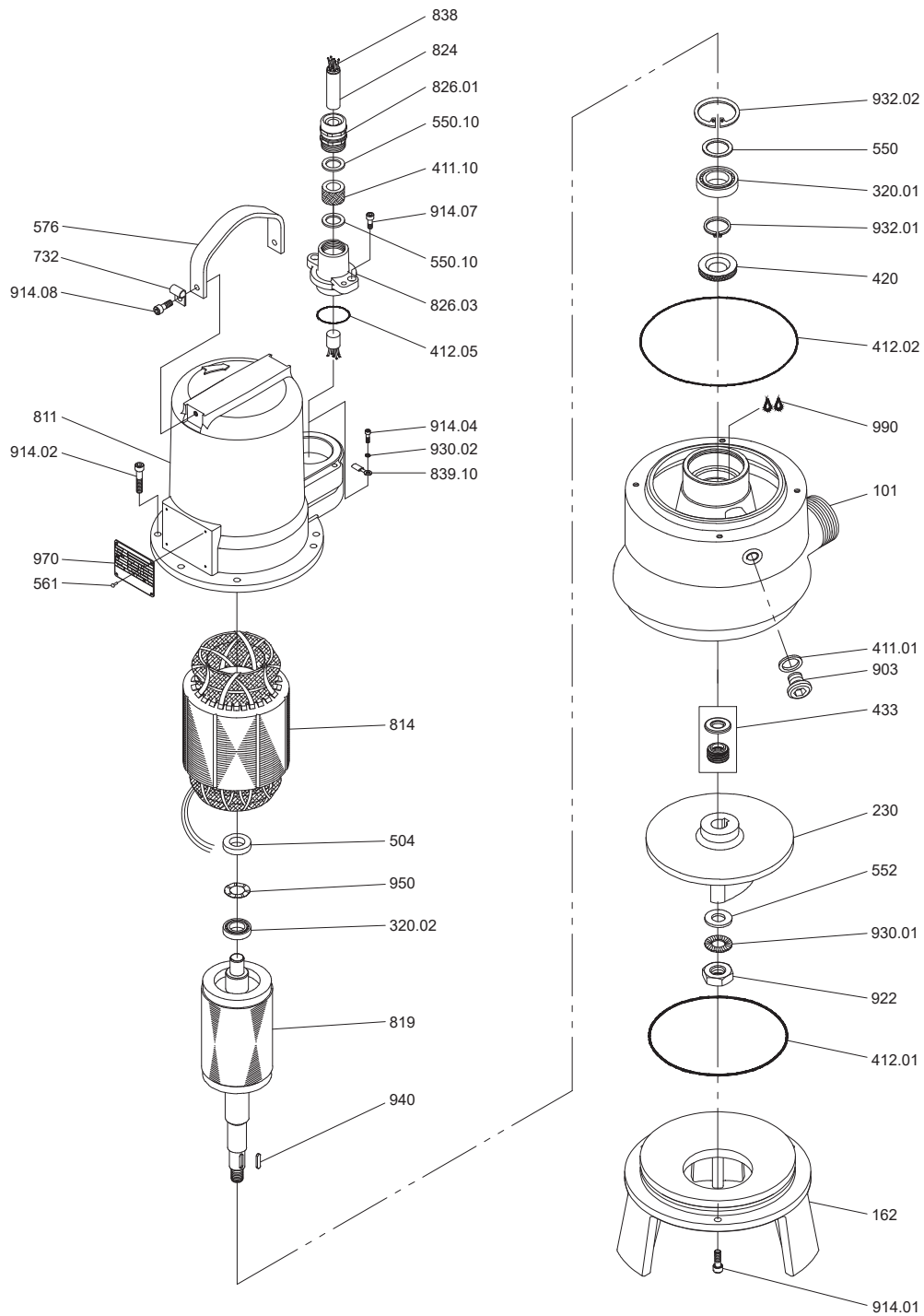

AP40.50.07

TM076817

7.1.2 AP50

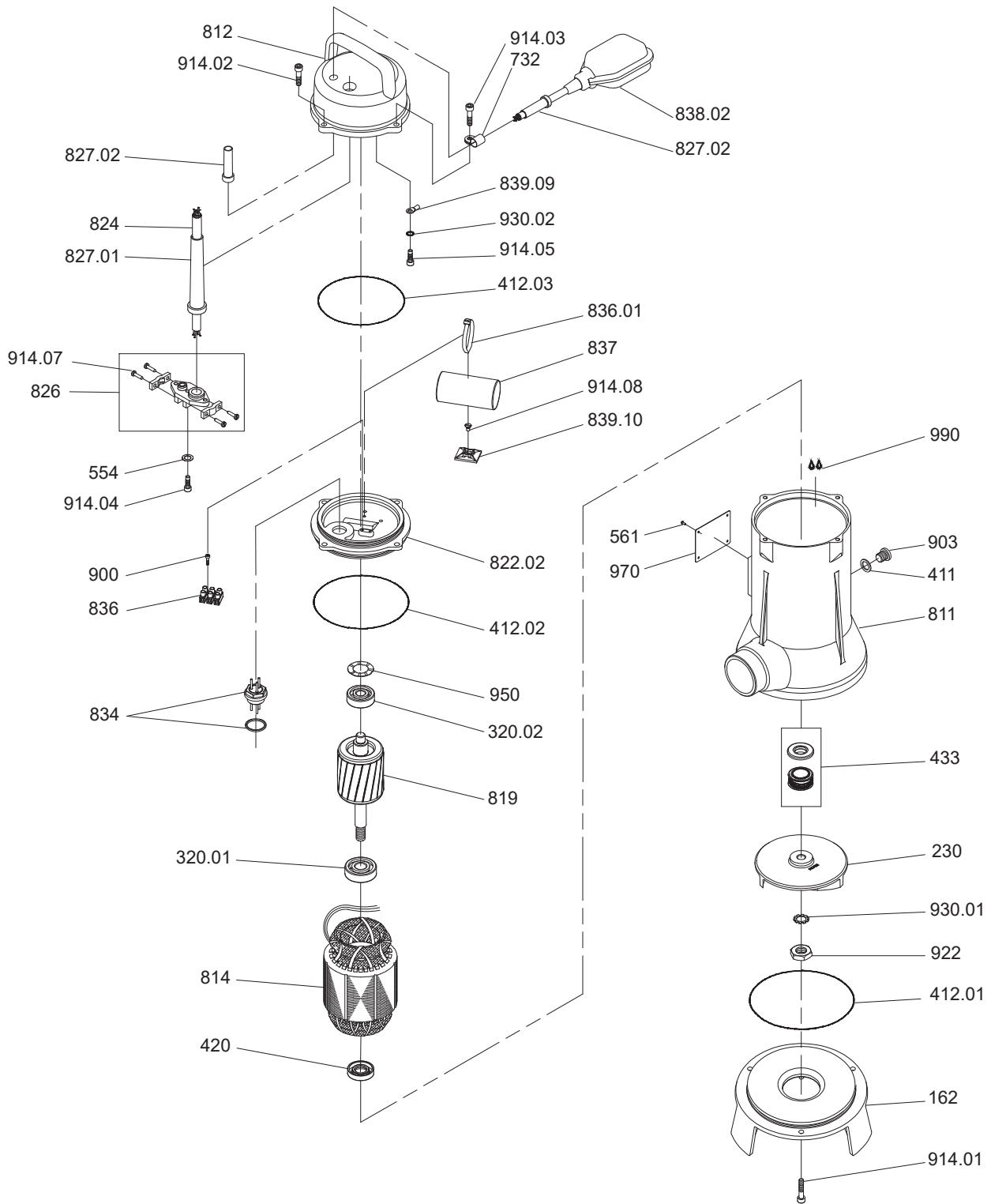

TM080056

AP50.50.11.1.

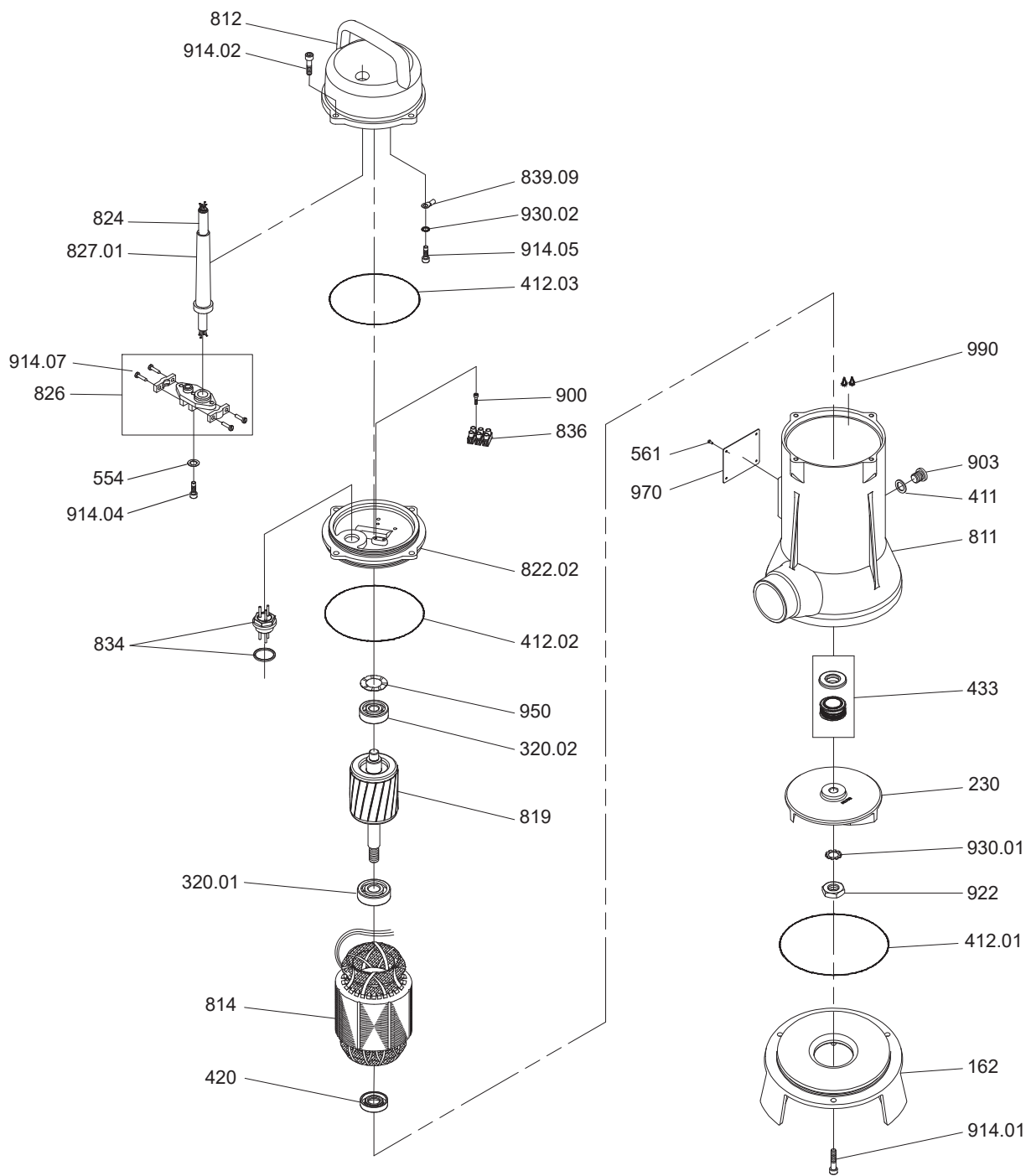

TM080057

AP50.50.11.3

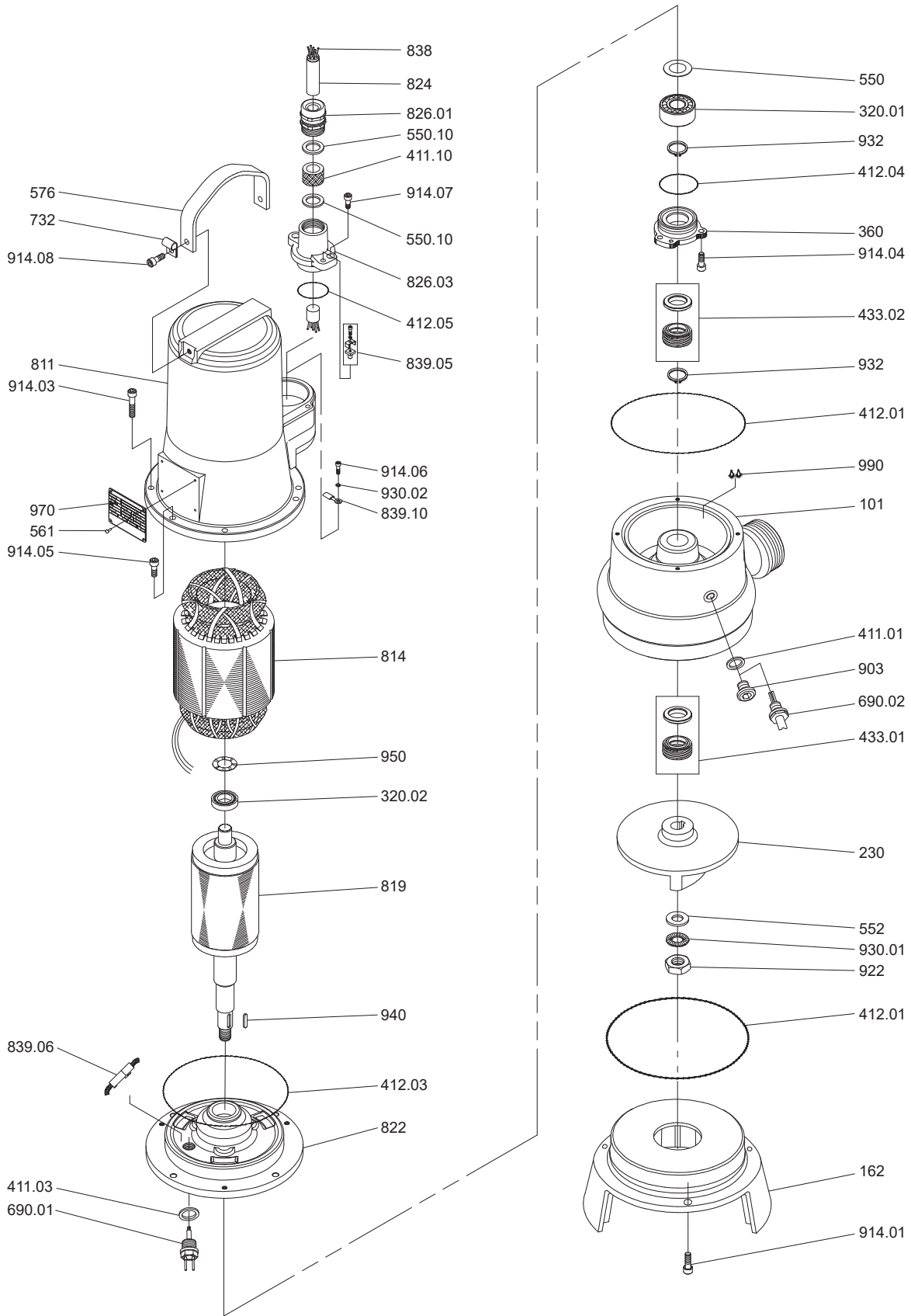

AP50.65.10

TM076812

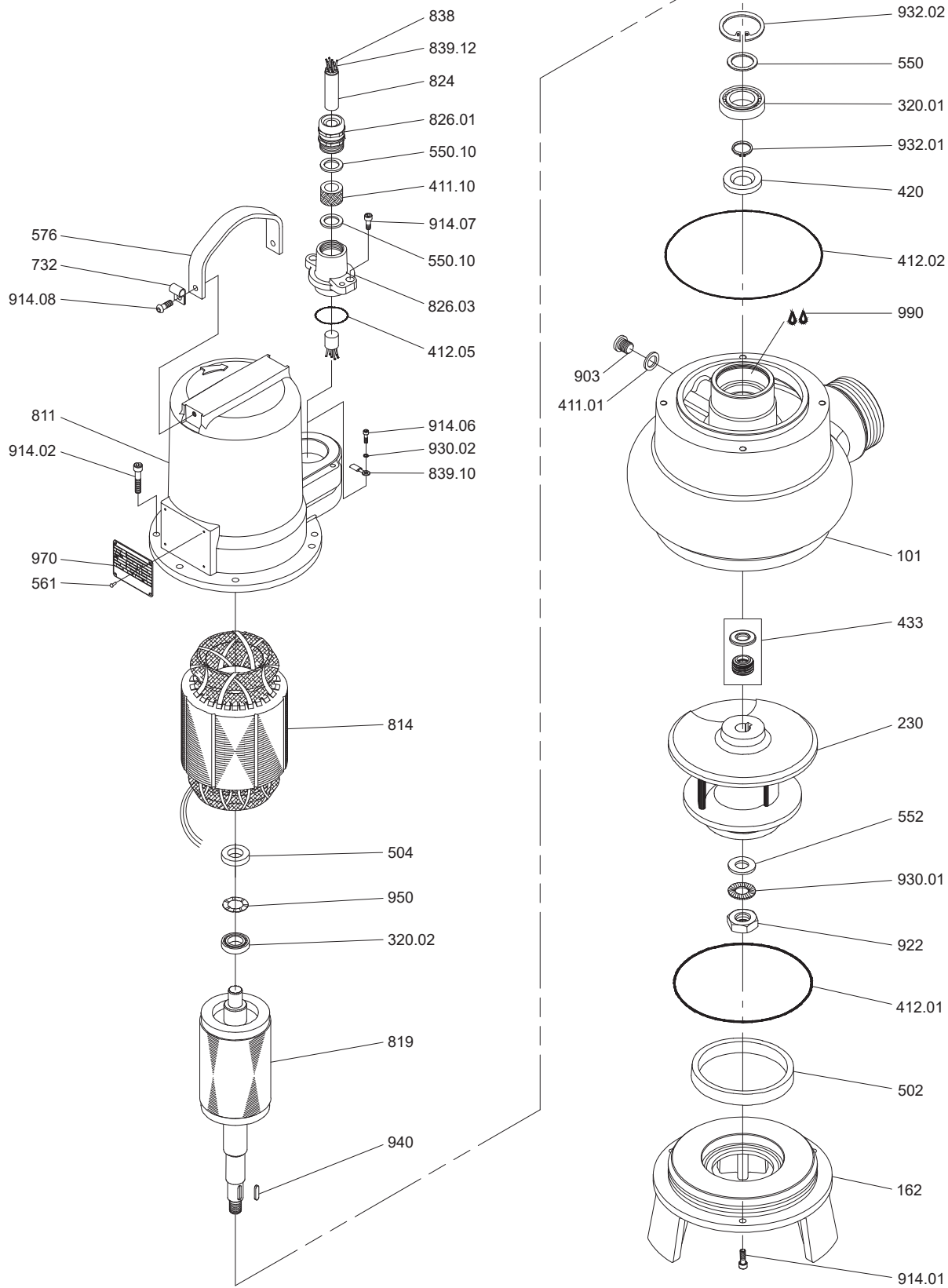

AP50.65.12

TM076818

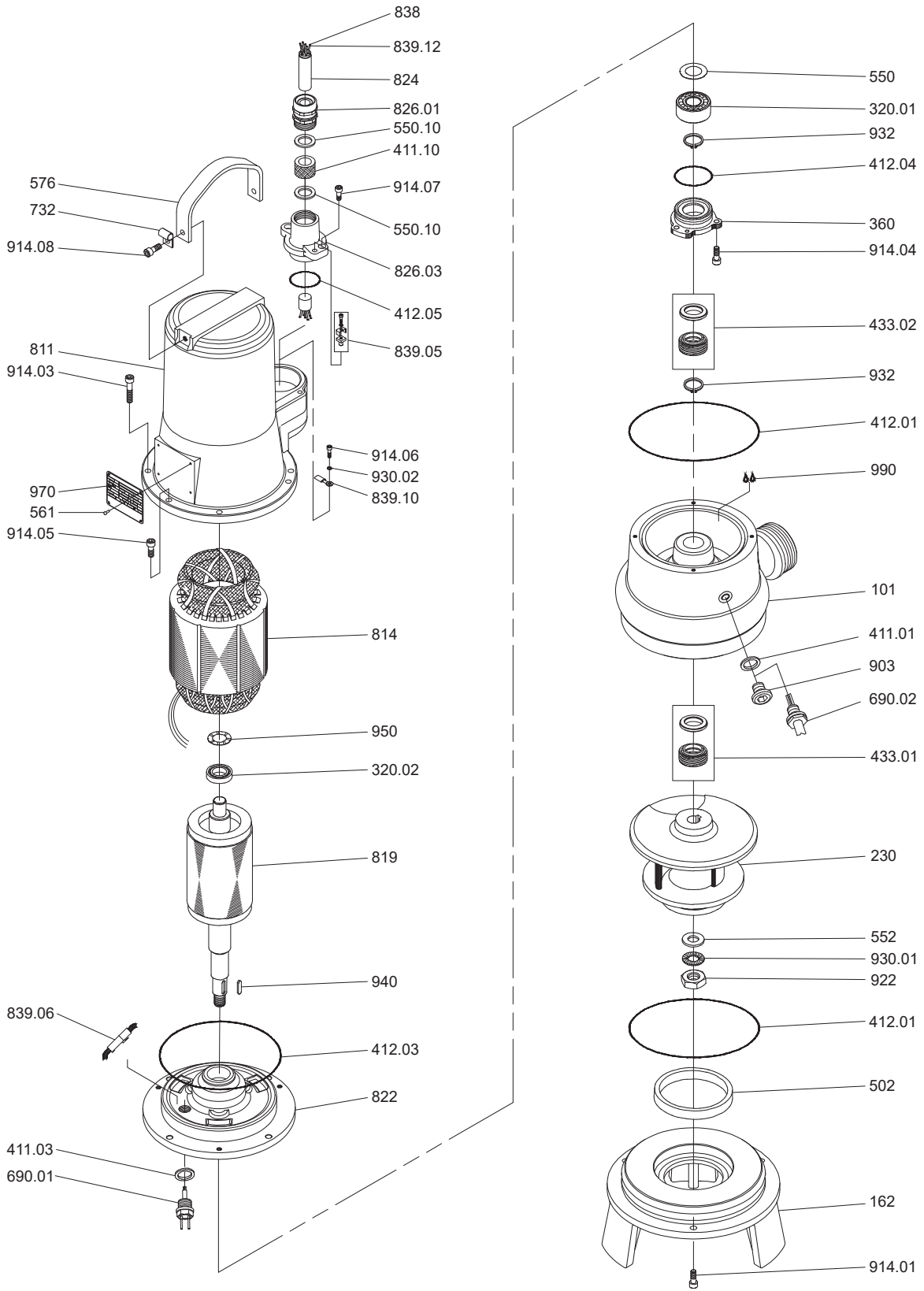

TM076811

AP50.65.18

7.1.3 AP60

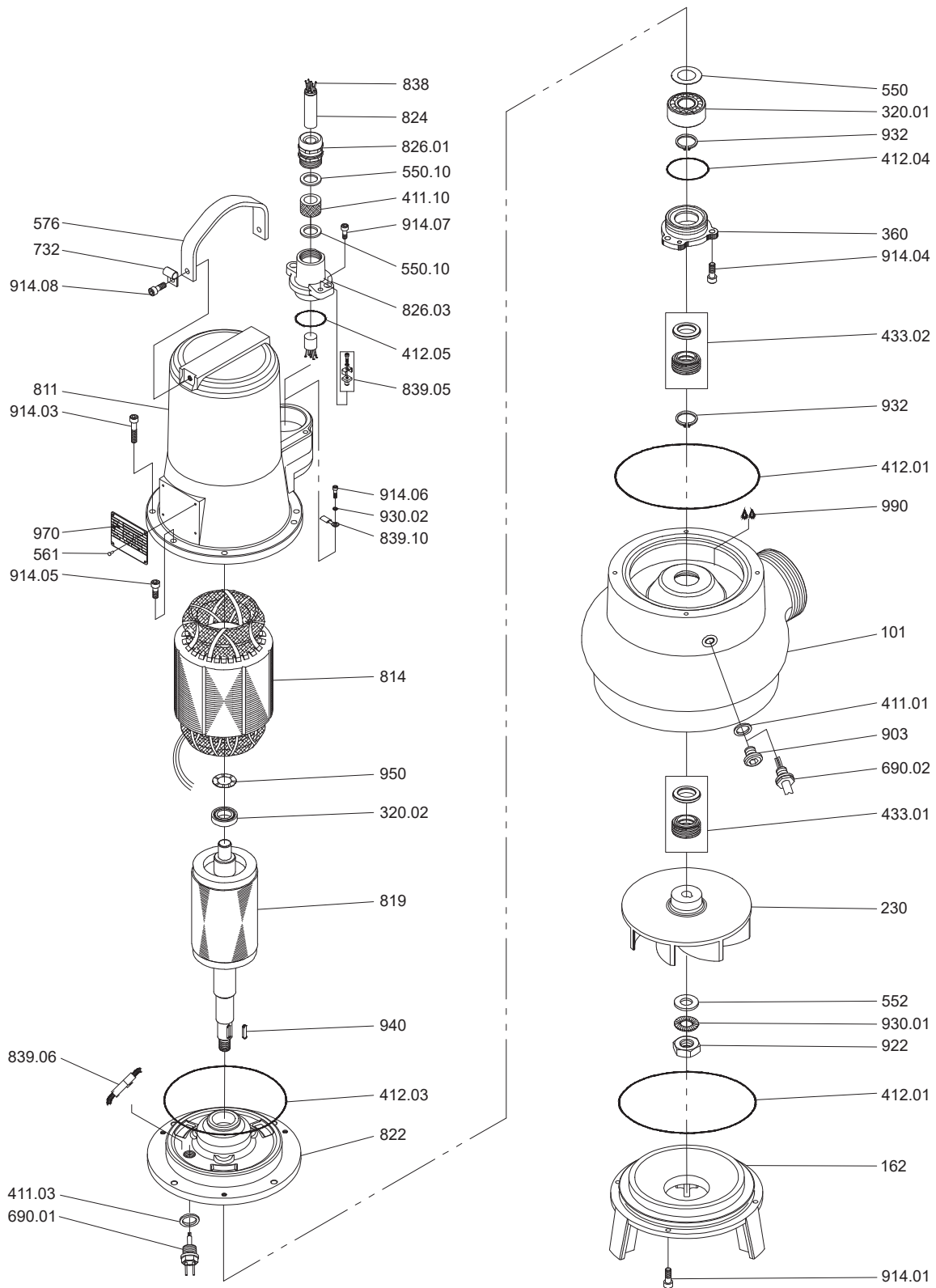

TM076813

AP60.65.08

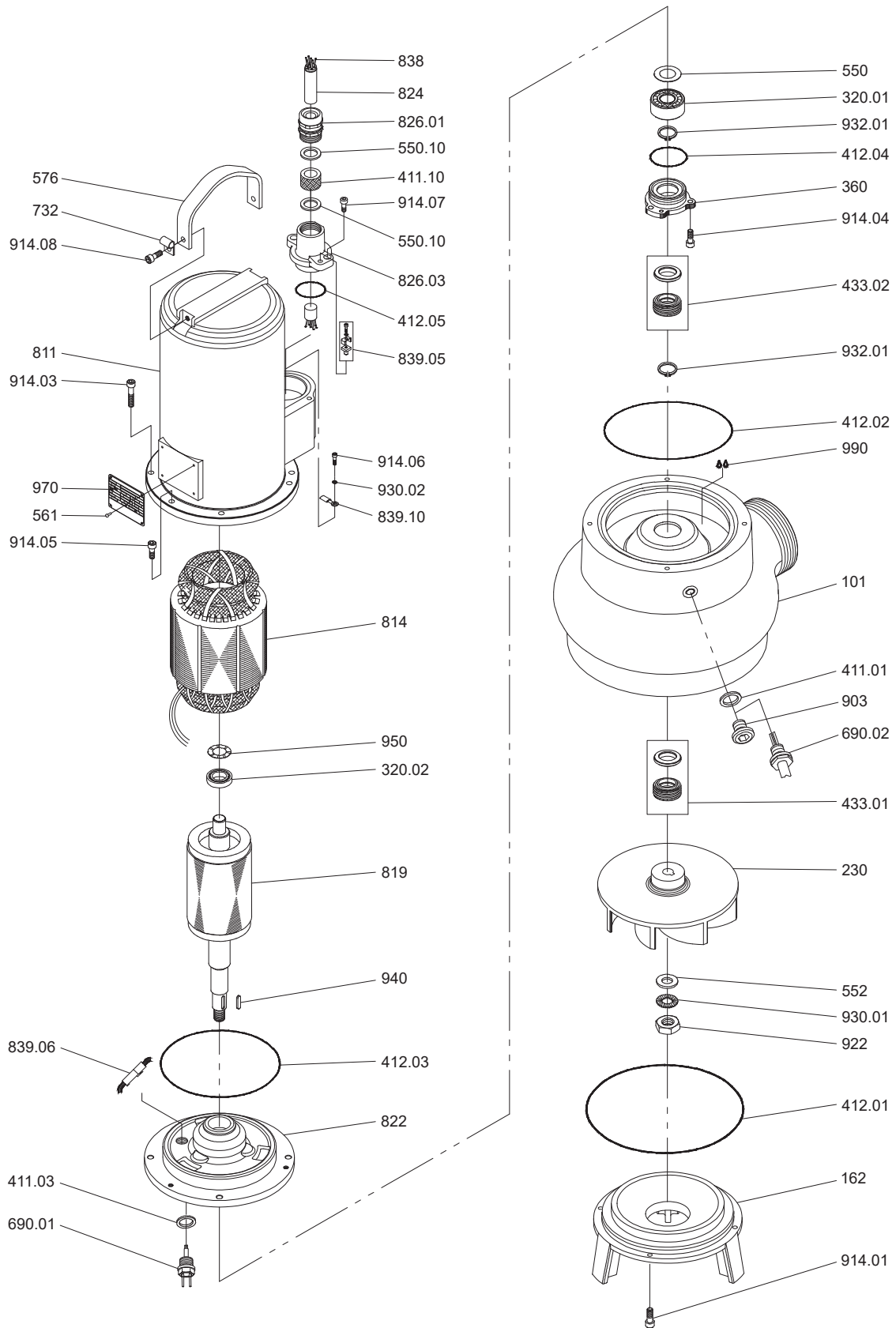

TM076816

AP60.65.18

7.1.4 AP70

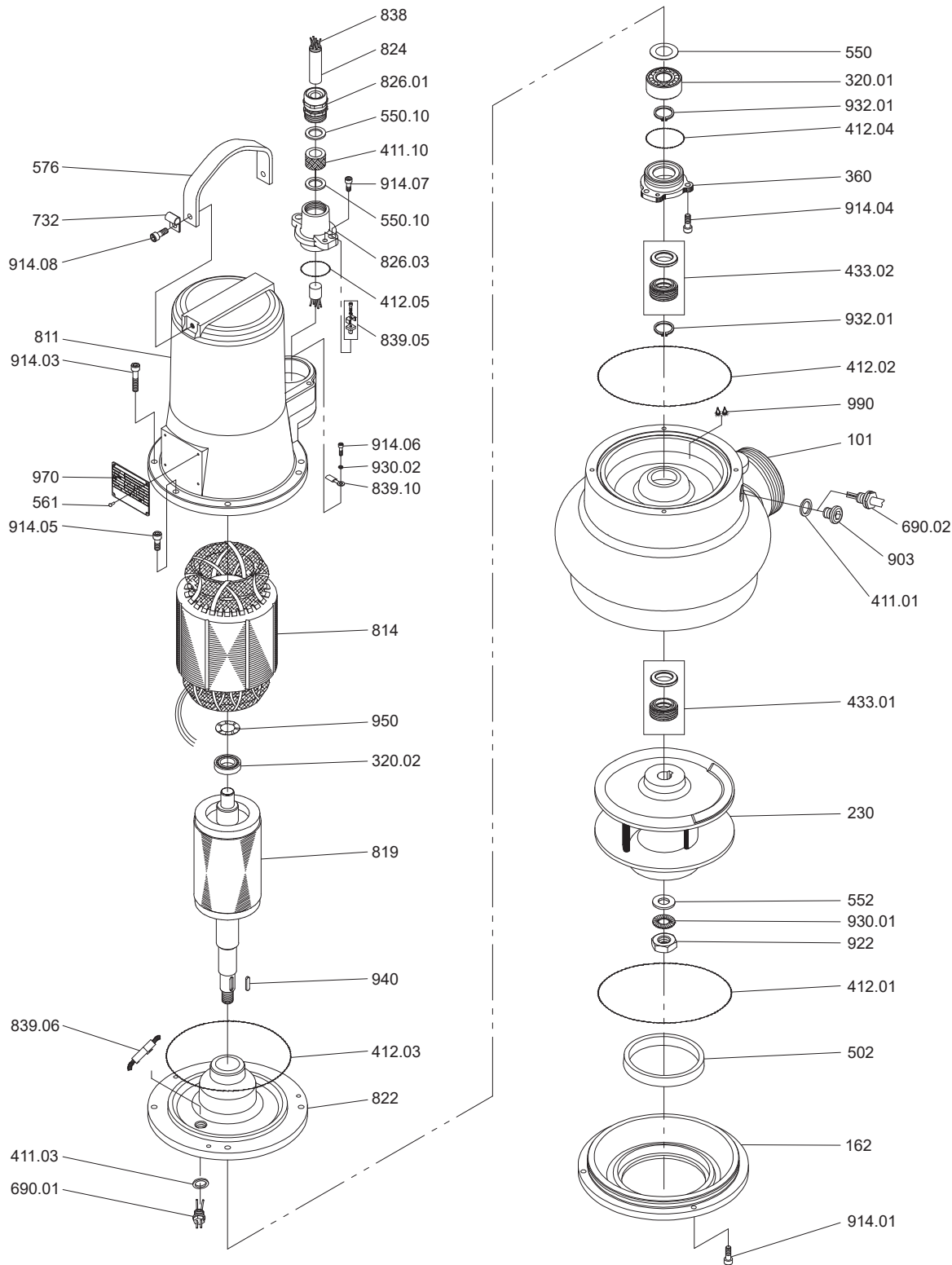

AP70.80.09

TM076814

7.1.5 AP80

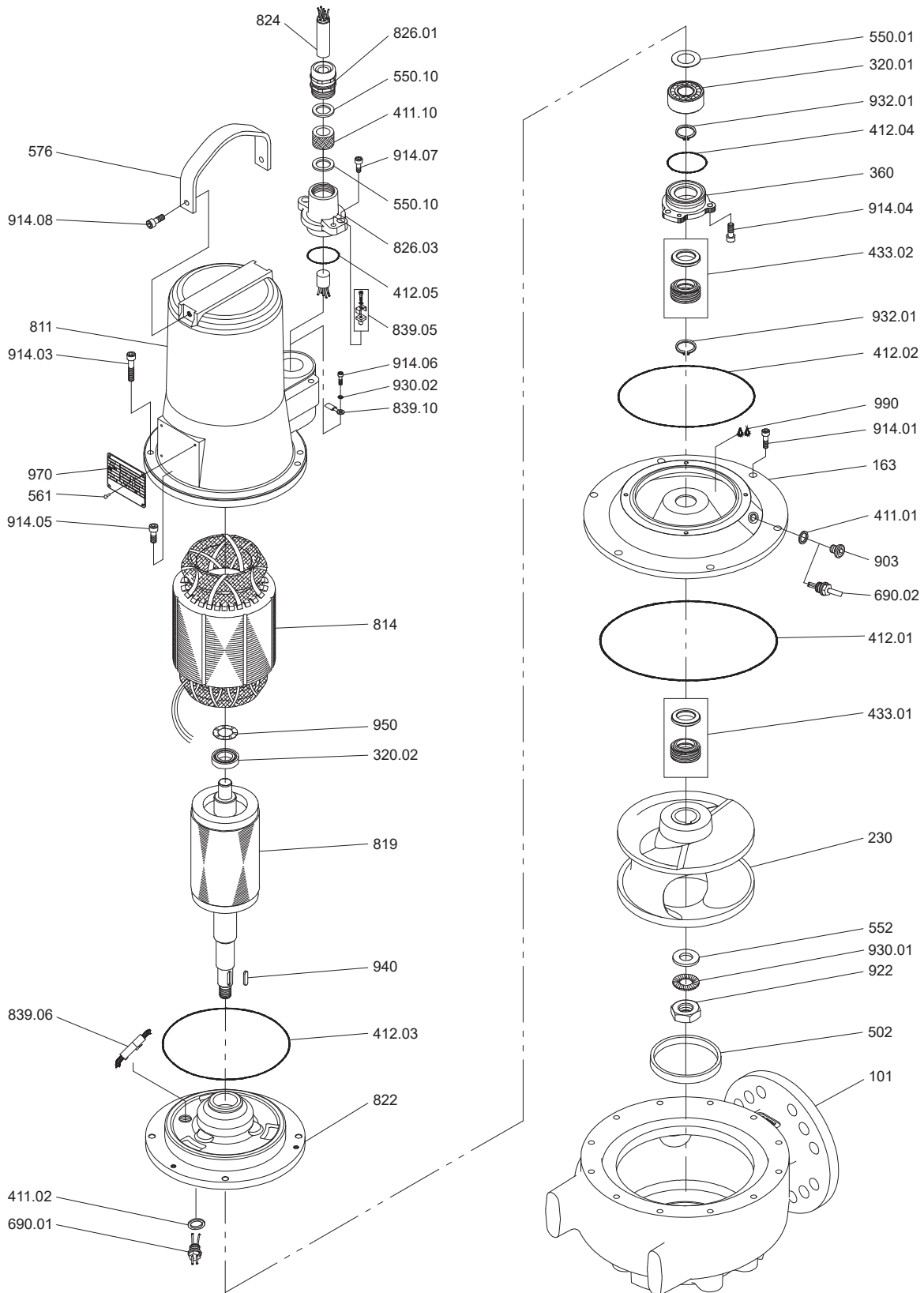

AP80.80.13

7.1.7 Material specification

AP40-50.50-70 range

Position	Description	Material
10	Plug set, 2 pole mini	
20	Plug set, 2 pole mini	
101	Pump housing	Cast iron
162	Suction cover	Cast iron
163	Pressure cover	Cast iron
230	Impeller	Cast iron
320.01	Angular ball bearing	
320.02	Grooved ball bearing	
360	Bearing cover	
411	Teflon sealing	
411.01	Fiber joint	
411.03	Fiber joint	
411.10	Sealing ring	EPDM
412.01	O-ring	NBR rubber
412.02	O-ring	NBR rubber
412.03	O-ring	NBR rubber
412.04	O-ring	NBR rubber
412.05	O-ring	NBR rubber
420	Radial shaft ring	
433	Mechanical seal	Hard metal, cast iron
433.01	Mechanical seal	Hard metal, cast iron
433.02	Mechanical seal	Hard metal, cast iron
502	Wear ring	
504	Pressure ring	
550	Adjusting washer	
550.10	Pressure ring	
552	Washer	
554	Washer	
561	Grooved drive stud	
576	Handle with coating	
690.01	Seal probe	
811	Motor housing	Cast iron
812	Motor housing cover	
814	Stator with winding	
819	Motor shaft with rotor	
822	Lower bearing cover	Cast iron
822.02	Lower bearing cover	
824	Rubber-sheathed cable	
826	Cable gland stuffing box	
826.01	Cable screwing with pull relief	
826.03	Cable inlet flange	Cast iron
827.01	Cable sleeve	NBR rubber
834	Cable inlet	
836	Strip terminal	
837	Capacitor	
839.06	Connection cable seal probe	
839.09	Cable socket	
839.10	Cable socket, isolated "ring- shaped"	
839.12	Cord end piece, brass-blank	
900	Cylinder screw	
903	Hexagon socket screw plug	
914.01	Cylinder screw	

Position	Description	Material
914.02	Cylinder screw	
914.03	Cylinder screw	
914.04	Cylinder screw	
914.05	Cylinder screw	
914.06	Cylinder screw	
914.07	Cylinder screw	
914.08	Cylinder screw	
922	Hexagon nut	
930.01	Tooth washer	
930.02	Tooth washer	
932	Circlip	
932.01	Circlip	
932.02	Circlip	
940	Fitting key	
950	Ball bearing complete disc	
970	Nameplate	
990	Motor oil	

AP80-100 range

Pos.	Description	Material
10	Plug set, 2 pole mini	
20	Plug set, 2 pole mini	
101	Pump housing	Cast iron
163	Pressure cover	Cast iron
230	Impeller	Cast iron
320.01	Angular ball bearing	
320.02	Grooved ball bearing	
360	Bearing cover	
411.01	Fiber joint	
411.02	Fiber joint	
411.03	Fiber joint	
411.10	Sealing ring	EPDM
412.01	O-ring	NBR rubber
412.02	O-ring	NBR rubber
412.03	O-ring	NBR rubber
412.04	O-ring	NBR rubber
412.05	O-ring	NBR rubber
412.06	O-ring	NBR rubber
412.07	O-ring	NBR rubber
433.01	Mechanical seal	Hard metal, cast iron
433.02	Mechanical seal	Hard metal, cast iron
502	Wear ring	
550.01	Supporting disk	
550.02	Washer	
550.10	Pressure ring	
552	Clamping disk	
561	Unriv stainless steel rivet, pan head	
576	Handle with coating	
690.01	Seal probe	
811	Motor housing	Cast iron
814	Stator with winding with thermal sensor	
819	Motor shaft with rotor	
822	Lower bearing cover	
824	Rubber-sheathed cable	

Pos.	Description	Material
826.01	Cable screwing with pull relief	
826.03	Cable inlet flange	Cast iron
826.04	Locking flange	Cast iron
839.05	Outside potential compensation	
839.10	Cable socket, isolated, "ring- shaped"	
839.12	Cord end piece, brass-blank	
903	Hexagon socket screw plug	
903.01	Hexagon socket screw plug	
914.01	Cylinder screw	
914.03	Cylinder screw	
914.04	Cylinder screw	
914.05	Cylinder screw	
914.06	Cylinder screw	
914.07	Cylinder screw	
914.08	Cylinder screw	
914.09	Cylinder screw	
922	Hexagon nut	
930.01	Tooth washer	
930.02	Tooth washer	
932.01	Circlip	
932.02	Circlip	
940	Fitting key	
950	Spring washer	
970	Nameplate	
990	Motor oil	

8. Product description

8.1 Features

AP 40-70

	Maximum solids size [mm]	Impeller type	Shaft seal		Ball bearing types	
			Motor side	Medium side	Upper	Lower
AP40	42	Vortex	Nitrile rubber	SIC/SIC	Deep groove	Deep groove
AP50	50		Nitrile rubber	SIC/SIC	Double row angular	Deep groove
AP50	50	1-channel	Nitrile rubber (1.2 kW)	SIC/SIC	Deep groove	Deep groove (1.2 kW)
			SIC/SIC (1.7 kW)			Double row angular (1.7 kW)
AP60	62	Vortex	SIC/SIC	SIC/SIC	Double row angular	Deep groove
AP70	70	1-channel	SIC/SIC	SIC/SIC	Double row angular	Deep groove

AP 80-100

	Maximum solids size [mm]	Impeller type	Shaft seal		Ball bearing types	
			Motor side	Medium side	Upper	Lower
AP80 (1.3 kW)	80	1-channel	SIC/SIC	SIC/SIC	Double row angular	Deep groove
AP80 (2.6 kW)		Vortex				
AP80 (2.0 kW)						
AP100 (2.9 kW)	100	1-channel				

8.1.1 Shaft seals

The pumps have two mechanical shaft seals separating the motor from the pumped liquid. The shaft seals are in the oil chamber. The primary seal is SIC/SIC and the secondary is Carbon/Ceramic.

8.1.2 Motor

Motor range

Power [kW]	Poles
0.7	4
0.8	4
0.9	4
1.0	4
1.2	2
1.3	4
1.8	4
2.0	2
2.6	4
2.9	4

8.1.3 Sensors

	AP40 (1-phase)	AP40-60	AP70
Thermal protection	Thermistor is enclosed in motor winding. It has an automatic reset after cooling down, does not require outside control.	External thermal switch must be connected (contact Grundfos).	Enclosed in motor winding, requires outside control through the signal wires of the power cable.
Oil chamber seal probe		-	Requires outside control through the signal wires of the power cable.
AP80-100			
Thermal protection	Enclosed in motor winding, requires outside control through the signal wires of the power cable.		
Oil chamber seal probe	Requires outside control through the signal wires of the power cable.		

8.2 Operating conditions

Operating mode	S1, S3 30% (for AP40 and AP50)
Liquid temperature	0-40 °C. For short periods, a temperature of up to 60 °C is allowed.
Maximum density of the medium	1040 kg/m ³
pH	6 – 11
Maximum installation depth	20 m
Operating pressure	6 bar
Regular cable length	10 m
Maximum starts per hour	15

 The sound pressure level of the pumps is lower than the limiting values stated in the EC Council directive 2006/42/EC relating to machinery.

8.3 Operating modes

 Never use these pumps for siphoning operation. The pumps must always be completely submerged in the pumped liquid.

The pumps are designed for continuous (S1) operation. In this operating mode, the pump can operate continuously without being stopped for cooling. Being completely submerged, the pump is sufficiently cooled by the surrounding liquid. During S1 operation, the maximum number of starts per hour is 15.

 The pumps must be completely submerged for continuous operation.

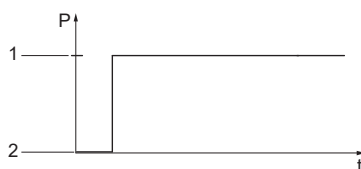

TM076798

S1 operation

Position	Description
1	Operation
2	Stop

The minimum liquid level is at the top of the pump housing.

For AP40 and AP50 pumps, intermittent (S3) operation between 40 °C and 60 °C liquid temperature is permitted up to 30%. S3 operation is a series of 10-minute duty cycles. Each cycle has a 3-minute period of constant load followed by a 7-minute period of rest. Thermal equilibrium is not reached during the cycle.

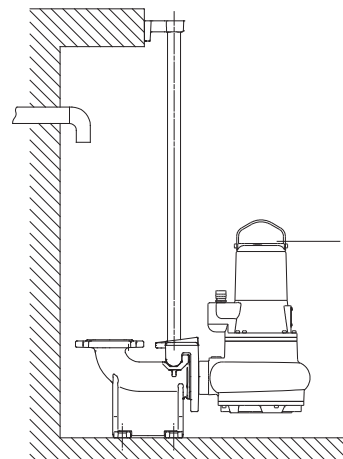

TM076796

Minimum liquid level

Position	Description
1	Minimum liquid level

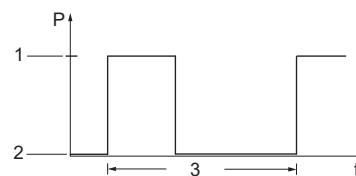

TM076800

S3 operation

Position	Description
1	Operation
2	Stop
3	Duty cycle

8.4 Pump controllers

Grundfos LC level controllers are available in two variants:

- LC 231 - compact solution with certified motor protection
- LC 241 - cabinet solution offering modularity and customisation

They are designed for single- or dual-pump installations. The Grundfos LC level controllers are ideal for pumps emptying and filling related to small wastewater transport, commercial buildings and tank-filling applications.

A controller can support up to five control levels for both analogue level transmitter or float switch operation. For emptying applications, the controller runs all pumps to empty the liquid from the tank or pit. The controller is equipped with Grundfos configurable input/output terminals, providing flexibility for all applications. Daily control, supervision and commissioning is straightforward with the intuitive and user-friendly interface.

The controller integrates smoothly into the Grundfos range of communication modules, ensuring an easy fit into any supervisory system such as SCADA or Grundfos CLOUD Solution. For further information, see the data booklet or installation and operating instructions on www.grundfos.com (Grundfos Product Center)

8.5 Frequency converter operation

Only AP100 pumps can be connected to a frequency converter. However, frequency converter operation often exposes the motor insulation system to a heavier load and causes the motor to be more noisy. In this product range, only negligible amounts of bearing currents occur during the use of a frequency converter.

8.6 Wiring diagrams

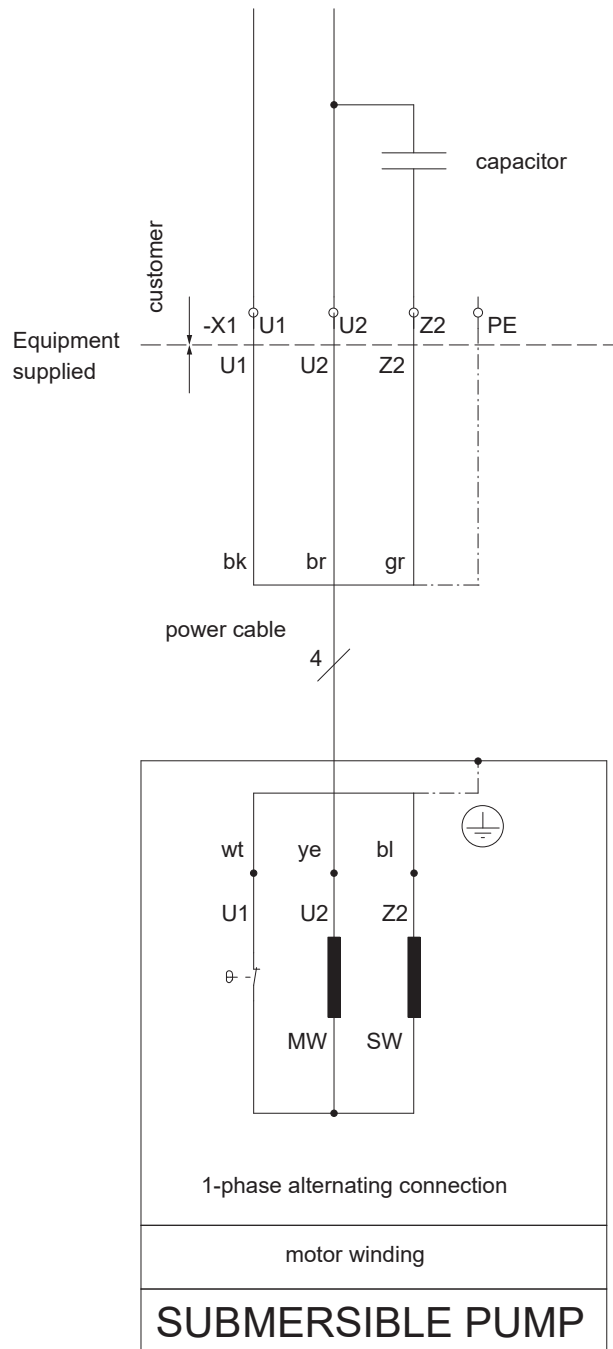

MW = main winding
 SW = start winding

TW076809

1-phase motor wiring diagram

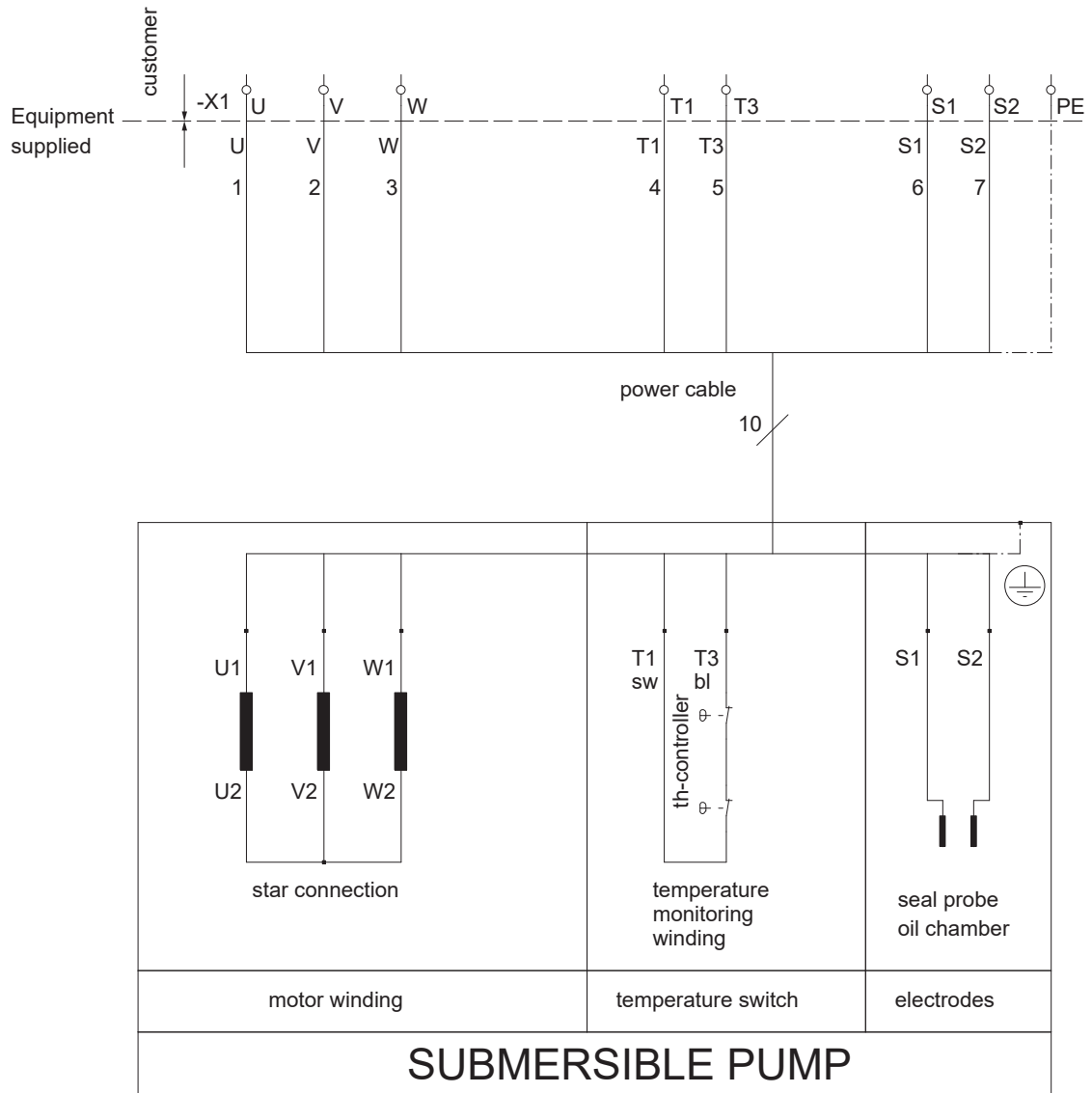

TM076810

3-phase motor wiring diagram

9. Performance curves

9.1 How to read the curve charts

The example below is a guide on how to read the performance curves for AP 40-70 and 80-100 pumps.

9.2 Performance curve conditions

The following conditions apply to the performance curves:

- Tolerances according to ISO 9906:2017, grade 3B.
- The curves apply to the pumping of airless water at a temperature of 20 °C and a kinematic viscosity of 1 mm²/s (1 cSt).
- The Eta curves show the efficiency of the pump:
 - Eta 1 is the overall efficiency of the pump (P_{hyd}/P_1).
 - Eta 2 is the hydraulic efficiency of the pump (P_{hyd}/P_2).

P_1 : Motor input power.

P_2 : Pump input power.

P_{hyd} : Power applied to the liquid by the pump.

- In case of other densities than 1000 kg/m³, the outlet pressure is proportional to the density.
- When pumping liquids with a density higher than 1000 kg/m³, motors with higher outputs must be used.

9.3 Calculation of total head

Calculation of total head

$$H_{total} = H_{geo} + H_{stat} + H_{dyn}$$

H_{geo}	Height difference between measuring points.
H_{stat}	Differential head between the inlet and the outlet side of the pump.
H_{dyn}	Calculated values based on the velocity of the pumped liquid on the inlet and the outlet side of the pump.

9.4 Performance tests

The requested duty point for every pump is tested according to ISO 9906:2017, grade 3B, and without certification.

9.5 Certificates

All pumps are performance tested before leaving the factory. The factory test report is based on the ISO 9906:2017 3B standard. Test reports can be ordered directly with the pump or separately based on the pump serial number. Other tests or third-party inspection certificates are available on request.

9.6 Witness test

According to ISO 9906:2017, the customer can witness the testing procedure. The witness test is not a certificate and will not result in a written statement from Grundfos. The witness test itself is the only guarantee that everything is carried out as prescribed in the testing procedure. If a witness test is required, the request must be stated on the order.

10. Performance curves and technical data

10.1 AP40

Performance curve

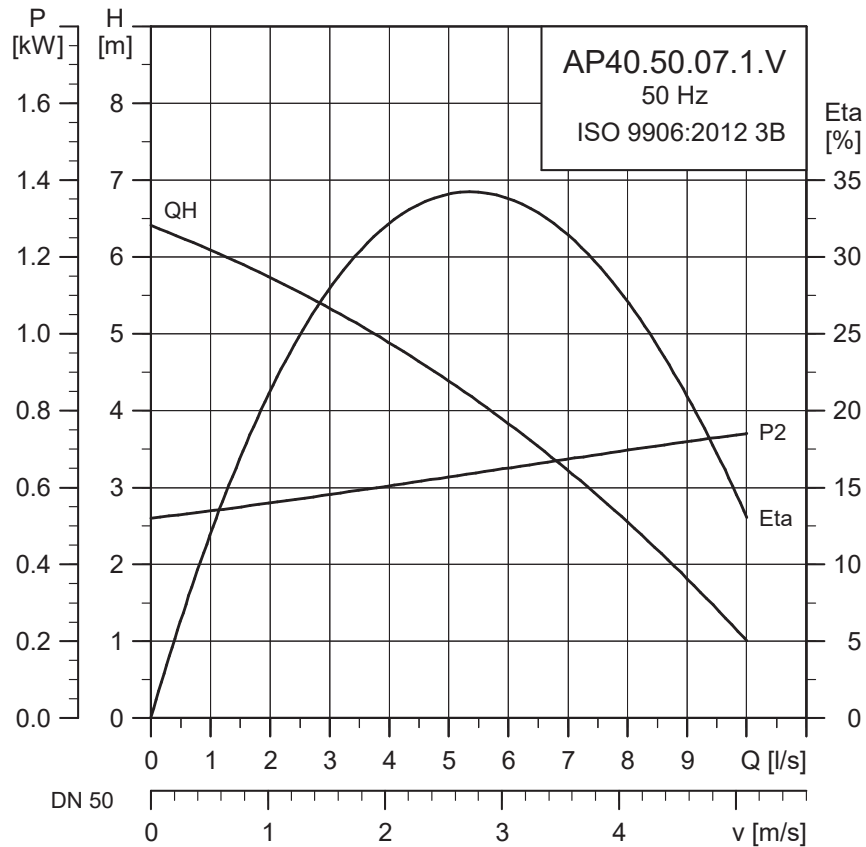

TM077221

Electrical data

Product number	Type	Voltage [V]	P1 [kW]	P2 [kW]	No of poles	Speed [rpm]	Starting method	I_N [A]	$\cos \phi$
99895440	AP40.50.07.1.V	230	1.0	0.7	4	1450	DOL	5	0.90

Pump data

Impeller type	Max. solids size [mm]	Max. number of starts per hour	Max. installation depth [m]	Enclosure class	Insulation class	Max. liquid temperature [°C]	pH
Vortex	40 mm	15	20	IP68	H	40	6-11

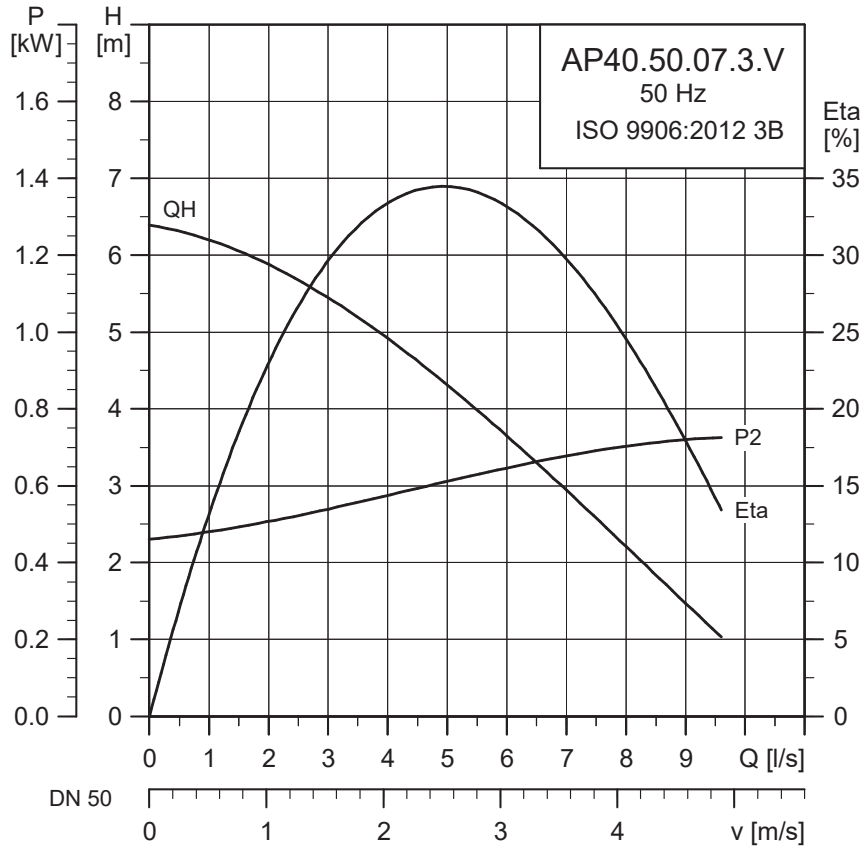

TM077222

Electrical data

Product number	Type	Voltage [V]	P1 [kW]	P2 [kW]	No of poles	Speed [rpm]	Starting method	I _N [A]	Cos φ
99895442	AP40.50.07.3.V	400	1.0	0.7	4	1450	DOL	2.3	0.75

Pump data

Impeller type	Max. solids size [mm]	Max. number of starts per hour	Max. installation depth [m]	Enclosure class	Insulation class	Max. liquid temperature [°C]	pH
Vortex	40 mm	15	20	IP68	H	40	6-11

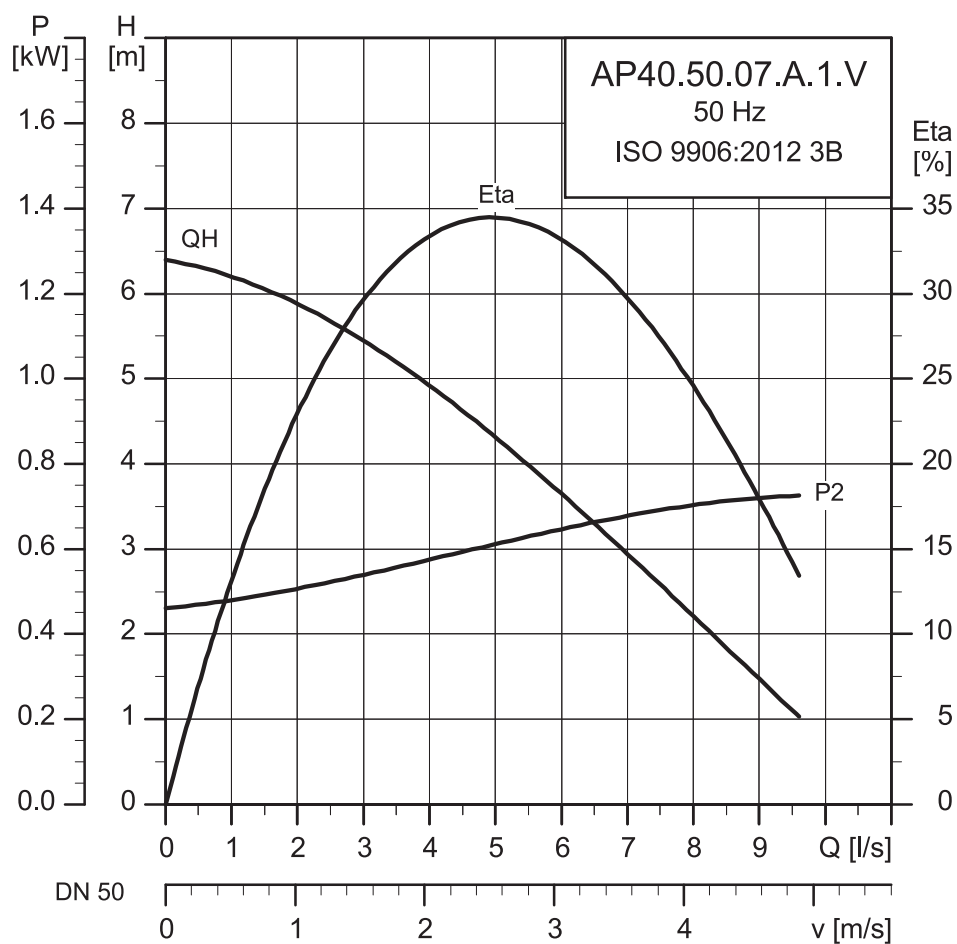

TM080428

Electrical data

Product number	Type	Voltage [V]	P1 [kW]	P2 [kW]	No of poles	Speed [rpm]	Starting method	I _N [A]	Cos φ
92543570	AP40.50.07.A.1.V	230	1	0.7	4	1.450	DOL	5	0.9

Pump data

Impeller type	Max. solid size	Max. number of starts per hour	Max. installation depth [m]	Enclosure class	Insulation class	Max. liquid temperature [°C]	pH
Vortex	50	15	20	IP68	H	40	6-11

10.2 AP50

Performance curve

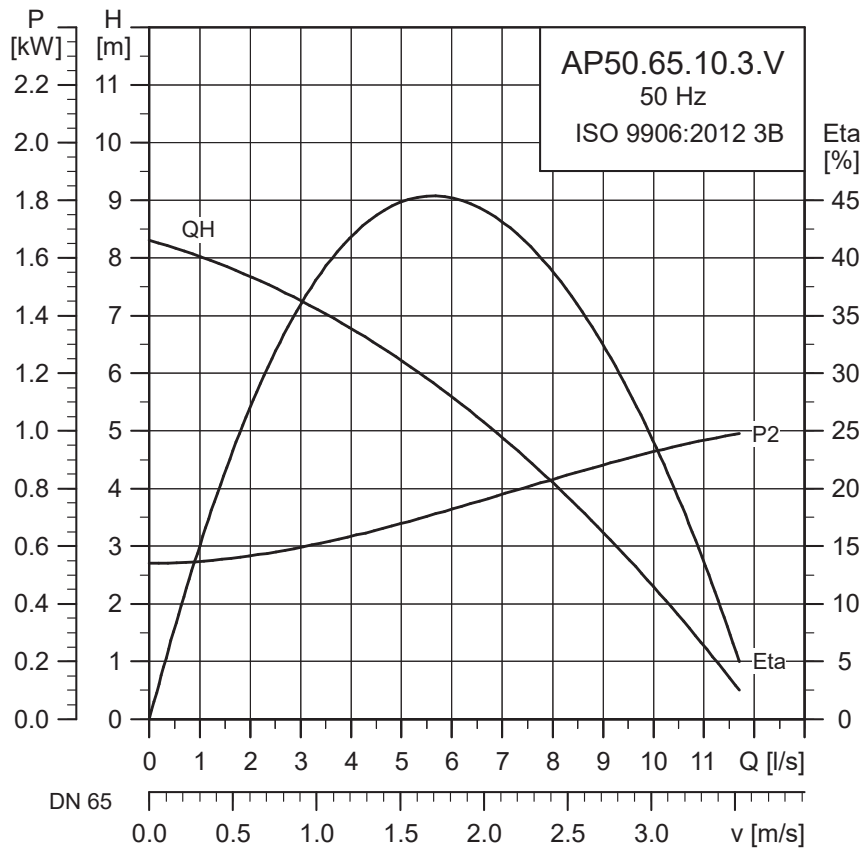

TM07723

Electrical data

Product number	Type	Voltage [V]	P1 [kW]	P2 [kW]	No of poles	Speed [rpm]	Starting method	I _N [A]	Cos φ
99895444	AP50.65.10.3.V	400	1.3	1.0	4	1450	DOL	2.6	0.7

Pump data

Impeller type	Max. solids size [mm]	Max. number of starts per hour	Max. installation depth [m]	Enclosure class	Insulation class	Max. liquid temperature [°C]	pH
Vortex	50 mm	15	20	IP68	H	40	6-11

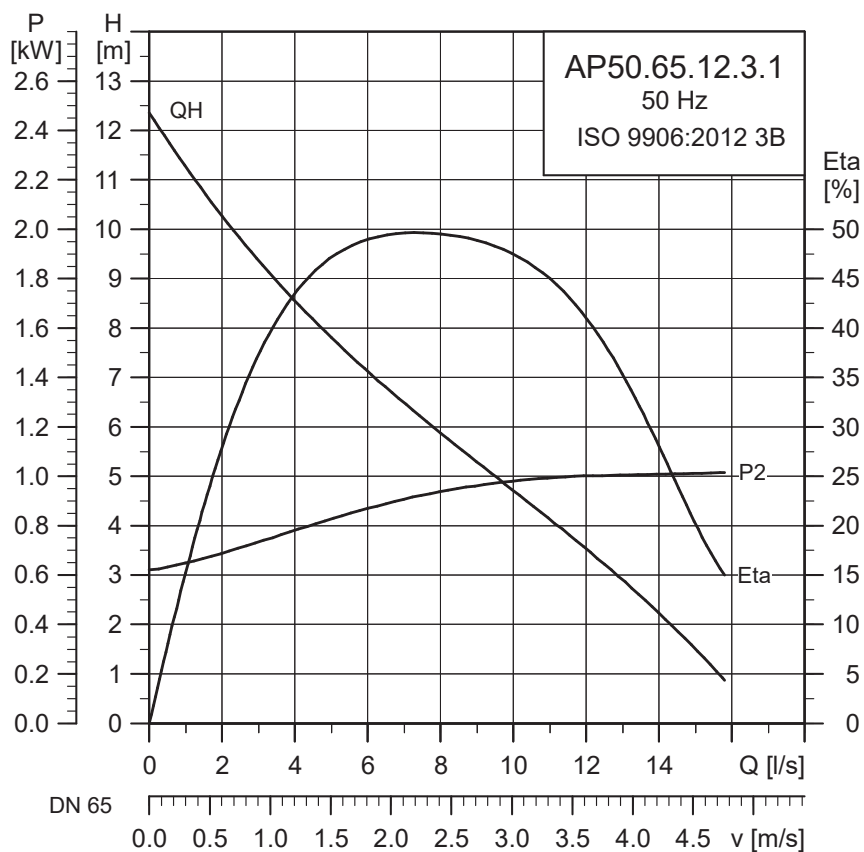

TM07724

Electrical data

Product number	Type	Voltage [V]	P1 [kW]	P2 [kW]	No of poles	Speed [rpm]	Starting method	I _N [A]	Cos φ
96002565	AP50.65.12.3.1	400	1.3	1.2	2	2900	DOL	2.3	0.84

Pump data

Impeller type	Max. solids size [mm]	Max. number of starts per hour	Max. installation depth [m]	Enclosure class	Insulation class	Max. liquid temperature [°C]	pH
1-channel	50 mm	15	20	IP68	H	40	6-11

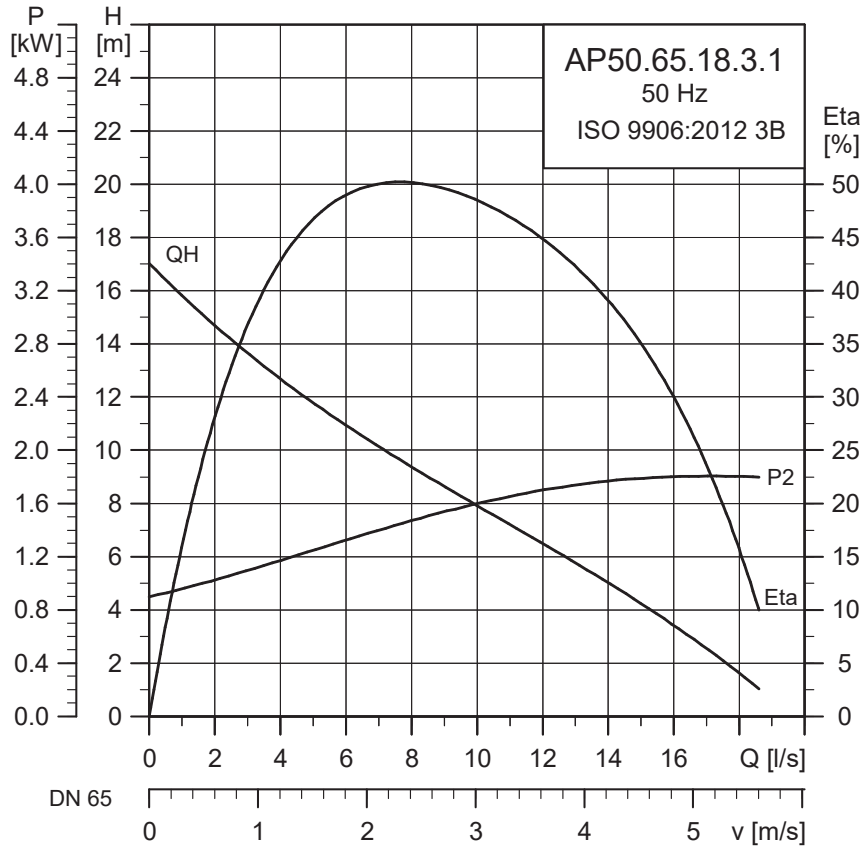

TM07725

Electrical data

Product number	Type	Voltage [V]	P1 [kW]	P2 [kW]	No of poles	Speed [rpm]	Starting method	I _N [A]	Cos φ
96002567	AP50.65.18.3.1	400	2.3	1.8	4	2900	DOL	3.8	0.76

Pump data

Impeller type	Max. solids size [mm]	Max. number of starts per hour	Max. installation depth [m]	Enclosure class	Insulation class	Max. liquid temperature [°C]	pH
1-channel	50 mm	15	20	IP68	H	40	6-11

10.3 AP50.50

Performance curve

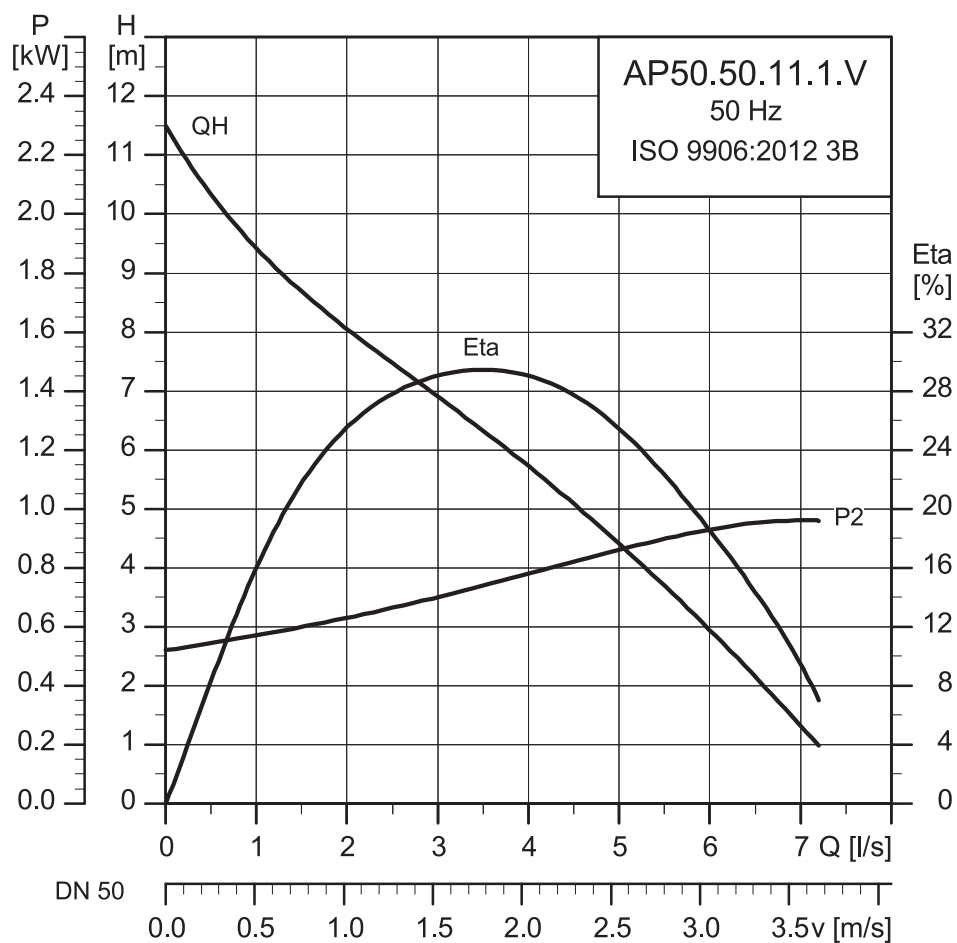

TM080425

Product number	Type	Voltage [V]	P1 [kW]	P2 [kW]	No of poles	Speed [rpm]	Starting method	I _N [A]	Cos φ
92543556	AP.50.50.11.1.V	230	1.5	1.1	2	2.900	DOL	6.5	0.99

Impeller type	Max. solid size [mm]	Max. number of starts per hour	Max. installation depth [m]	Enclosure class	Insulation class	Max. liquid temperature [°C]	pH
Vortex	50	15	20	IP68	H	40	6-11

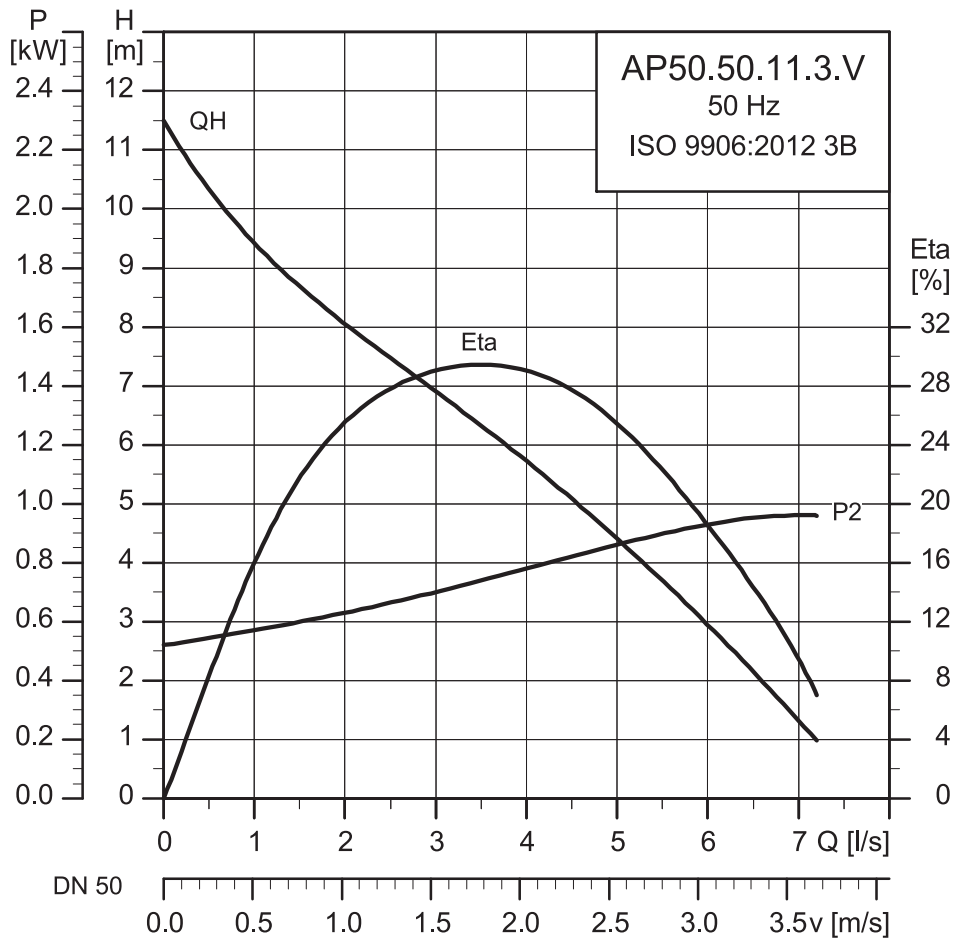

TM080426

Product number	Type	Voltage [V]	P1 [kW]	P2 [kW]	No of poles	Speed [rpm]	Starting method	I _N [A]	Cos φ
92543558	AP.50.50.11.3.V	400	1.5	1.1	2	2.900	DOL	2.5	0.87

Impeller type	Max. solid size [mm]	Max. number of starts per hour	Max. installation depth [m]	Enclosure class	Insulation class	Max. liquid temperature [°C]	pH
Vortex	50	15	20	IP68	H	40	6-11

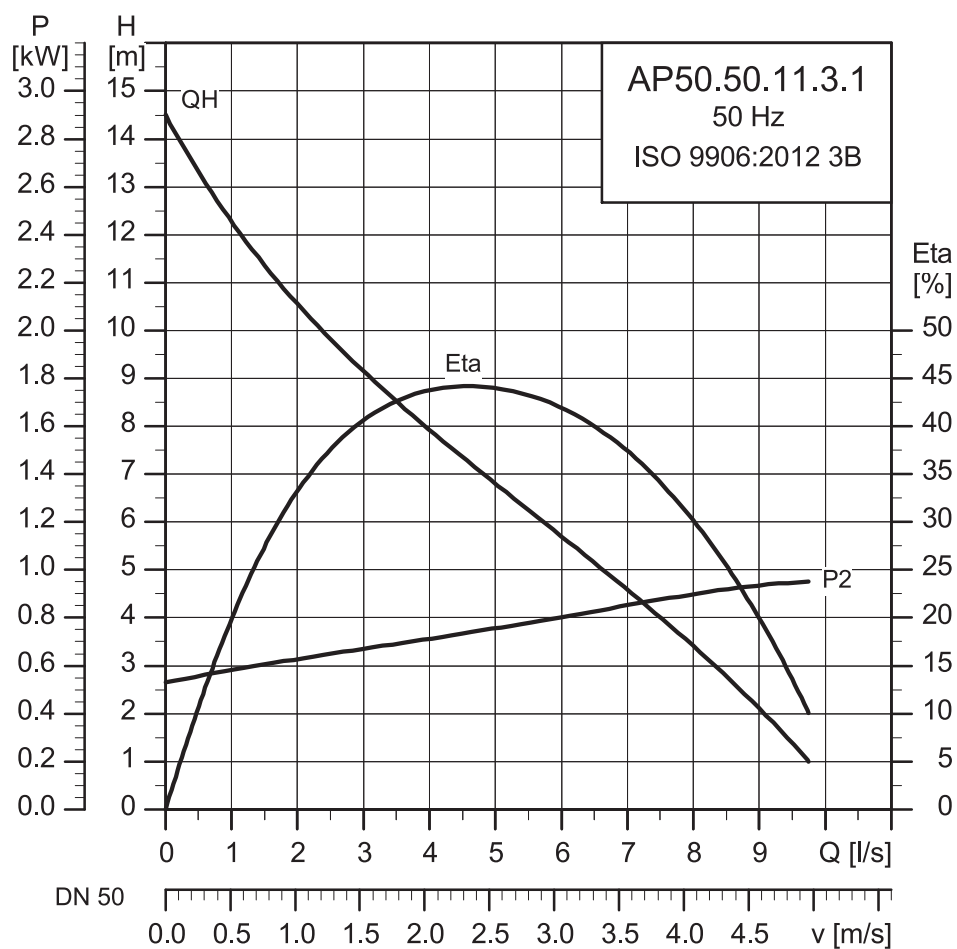

TM080427

Product number	Type	Voltage [V]	P1 [kW]	P2 [kW]	No of poles	Speed [rpm]	Starting method	I _N [A]	Cos φ
92543559	AP.50.50.11.3.1	400	1.5	1.1	2	2.900	DOL	2.5	0.87

Impeller type	Max. solid size [mm]	Max. number of starts per hour	Max. installation depth [m]	Enclosure class	Insulation class	Max. liquid temperature [°C]	pH
1-channel	50	15	20	IP68	H	40	6-11

10.4 AP60

Performance curve

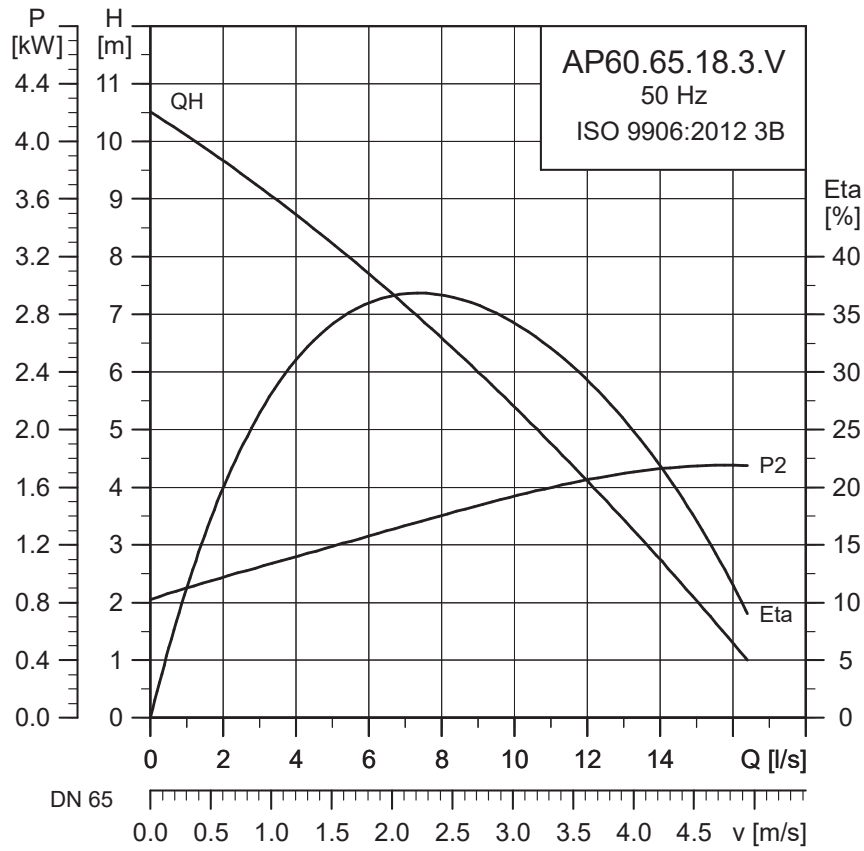

TM077227

Electrical data

Product number	Type	Voltage [V]	P1 [kW]	P2 [kW]	No of poles	Speed [rpm]	Starting method	I _N [A]	Cos φ
99895445	AP60.65.18.3.V	400	2.3	1.8	4	1450	DOL	2.4	0.8

Pump data

Impeller type	Max. solids size [mm]	Max. number of starts per hour	Max. installation depth [m]	Enclosure class	Insulation class	Max. liquid temperature [°C]	pH
Vortex	60 mm	15	20	IP68	H	40	6-11

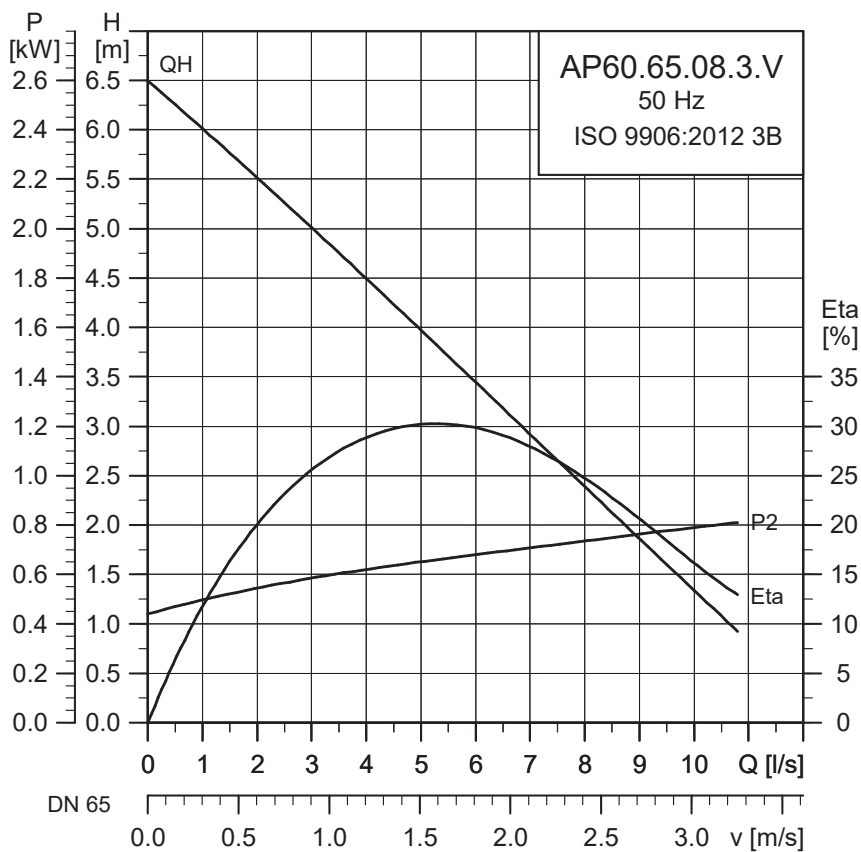

TM077226

Electrical data

Product number	Type	Voltage [V]	P1 [kW]	P2 [kW]	No of poles	Speed [rpm]	Starting method	I _N [A]	Cos φ
99895443	AP60.65.08.3.V	400	1.1	0.8	4	1450	DOL	2.6	0.7

Pump data

Impeller type	Max. solids size [mm]	Max. number of starts per hour	Max. installation depth [m]	Enclosure class	Insulation class	Max. liquid temperature [°C]	pH
Vortex	60 mm	15	20	IP68	H	40	6-11

10.5 AP70

Performance curve

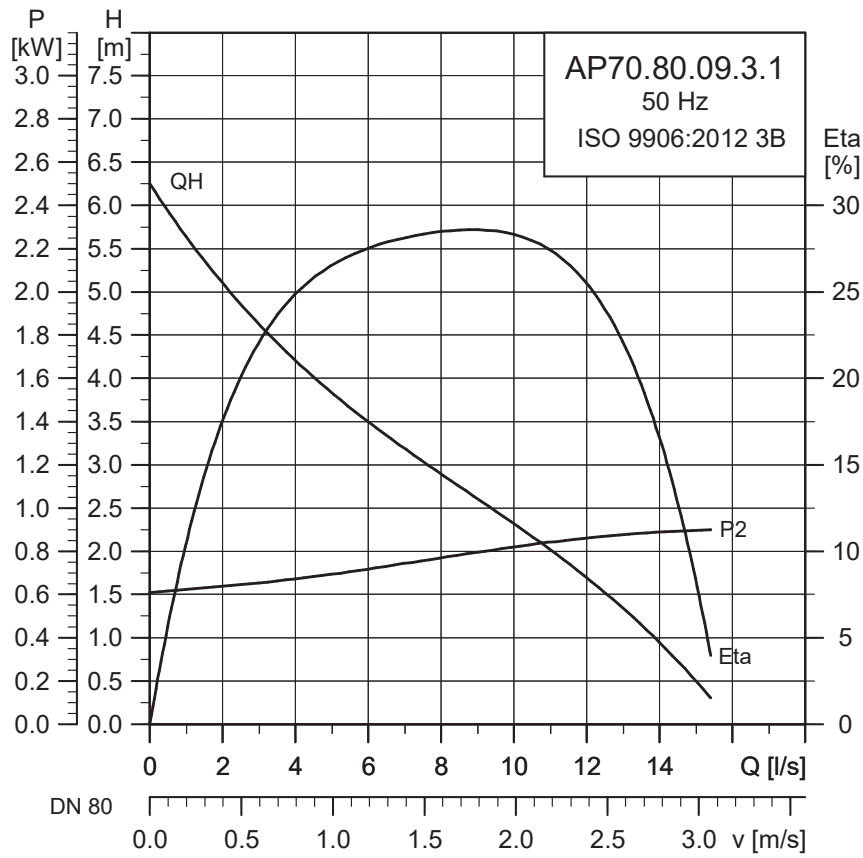

TM077228

Electrical data

Product number	Type	Voltage [V]	P1 [kW]	P2 [kW]	No of poles	Speed [rpm]	Starting method	I _N [A]	Cos φ
99895446	AP70.80.09.3.1	400	1.2	0.9	4	1450	DOL	2.6	0.70

Pump data

Impeller type	Max. solids size [mm]	Max. number of starts per hour	Max. installation depth [m]	Enclosure class	Insulation class	Max. liquid temperature [°C]	pH
1-channel	70 mm	15	20	IP68	H	40	6-11

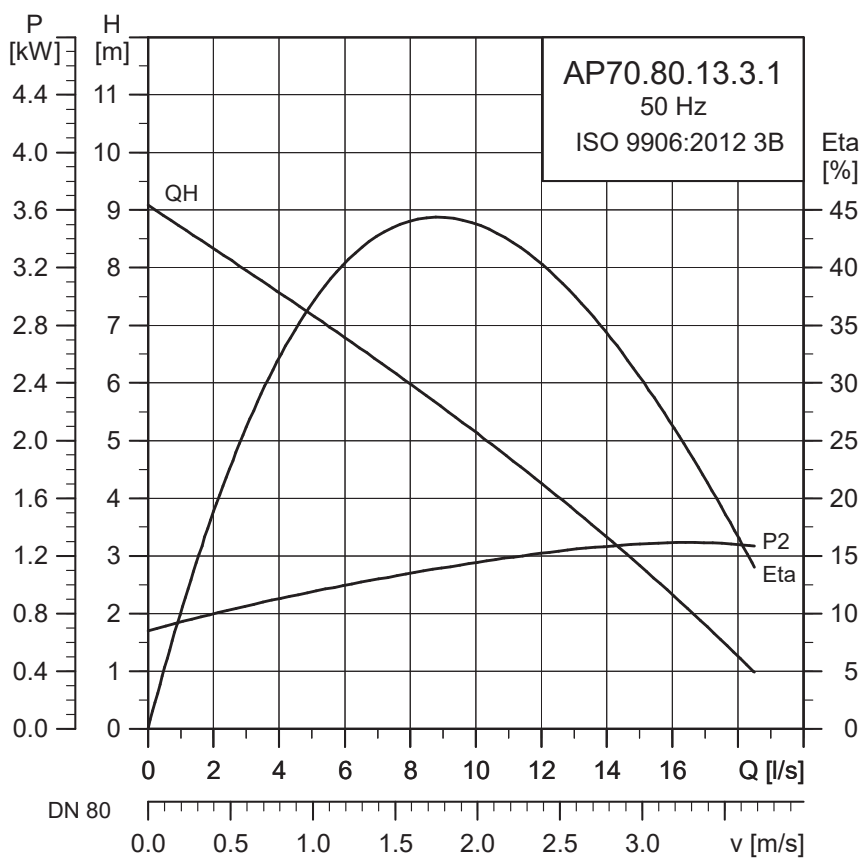

TM077229

Electrical data

Product number	Type	Voltage [V]	P1 [kW]	P2 [kW]	No of poles	Speed [rpm]	Starting method	I _N [A]	Cos φ
96002592	AP70.80.13.3.1	400	1.7	1.3	4	1450	DOL	3.3	0.78

Pump data

Impeller type	Max. solids size [mm]	Max. number of starts per hour	Max. installation depth [m]	Enclosure class	Insulation class	Max. liquid temperature [°C]	pH
1-channel	70 mm	15	20	IP68	H	40	6-11

10.6 AP80

Performance curve

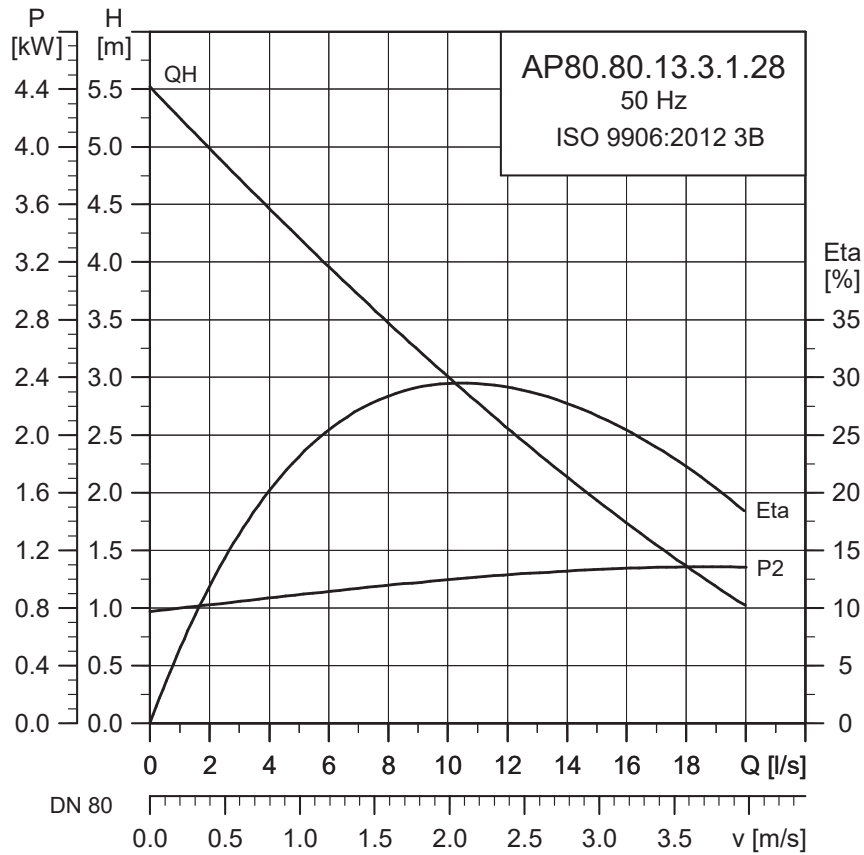

TM077230

Electrical data

Product number	Type	Voltage [V]	P1 [kW]	P2 [kW]	No of poles	Speed [rpm]	Starting method	I _N [A]	Cos φ
99895447	AP80.80.13.3.1.28	400	1.7	1.3	4	1450	DOL	3.3	0.77

Pump data

Impeller type	Max. solids size [mm]	Max. number of starts per hour	Max. installation depth [m]	Enclosure class	Insulation class	Max. liquid temperature [°C]	pH
1-channel	80 mm	15	20	IP68	H	40	6-11

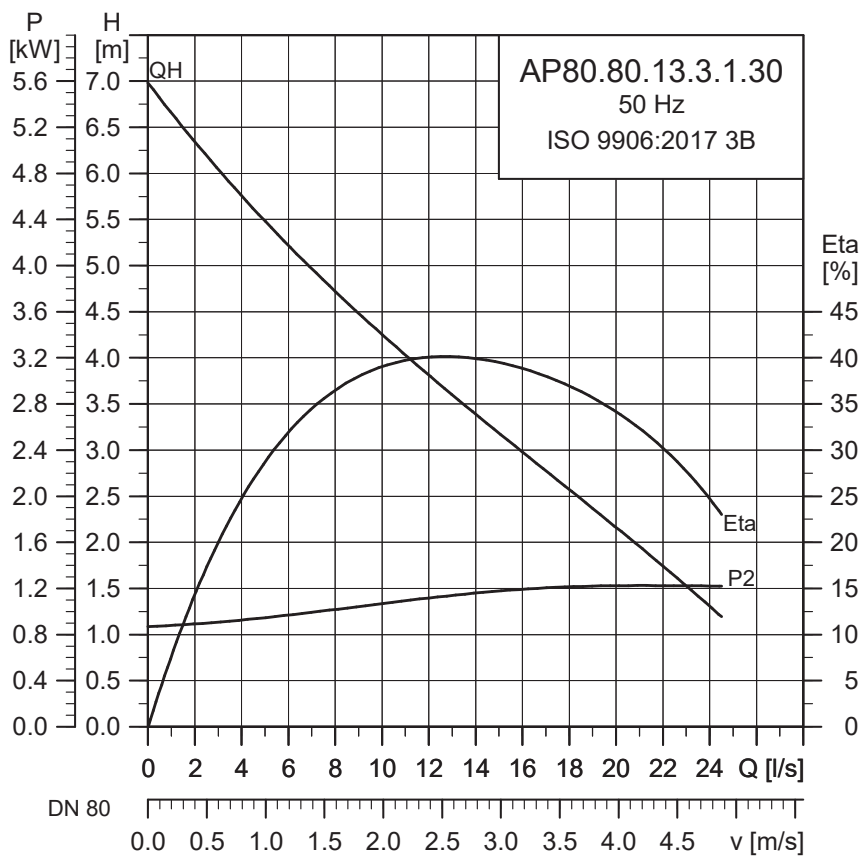

TM077231

Electrical data

Product number	Type	Voltage [V]	P1 [kW]	P2 [kW]	No of poles	Speed [rpm]	Starting method	I _N [A]	Cos φ
99895448	AP80.80.13.3.1.30	400	1.7	1.3	4	1450	DOL	3.3	0.7

Pump data

Impeller type	Max. solids size [mm]	Max. number of starts per hour	Max. installation depth [m]	Enclosure class	Insulation class	Max. liquid temperature [°C]	pH
1-channel	80 mm	15	20	IP68	H	40	6-11

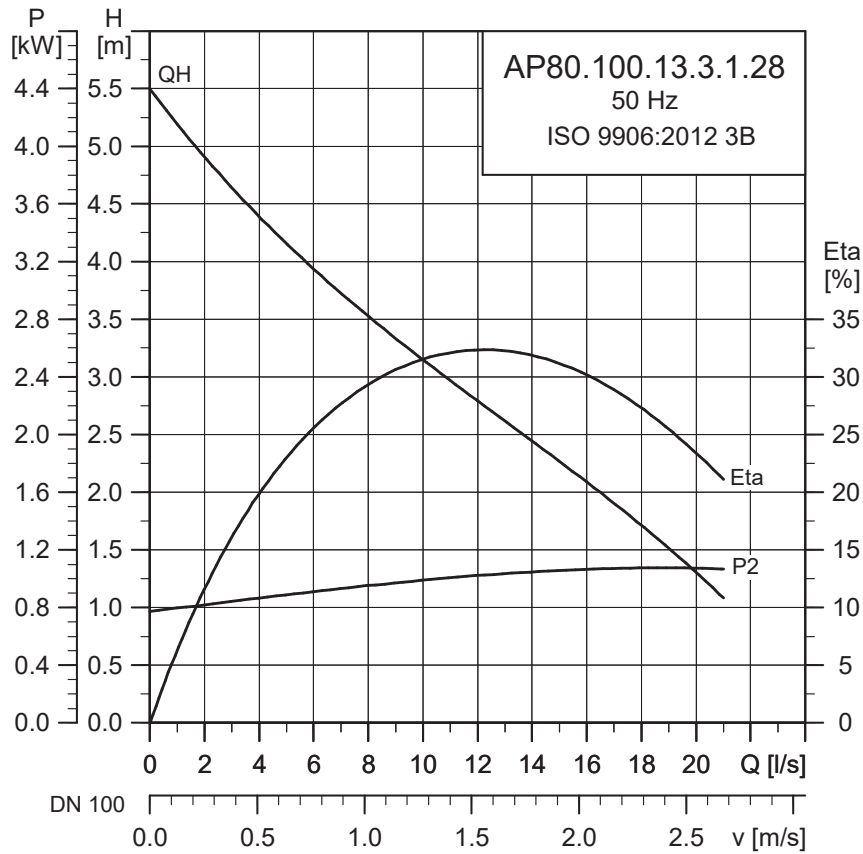

TM077234

Electrical data

Product number	Type	Voltage [V]	P1 [kW]	P2 [kW]	No of poles	Speed [rpm]	Starting method	I _N [A]	Cos φ
99895449	AP80.100.13.3.1.28	400	1.7	1.3	4	1450	DOL	3.3	0.77

Pump data

Impeller type	Max. solids size [mm]	Max. number of starts per hour	Max. installation depth [m]	Enclosure class	Insulation class	Max. liquid temperature [°C]	pH
1-channel	80 mm	15	20	IP68	H	40	6-11

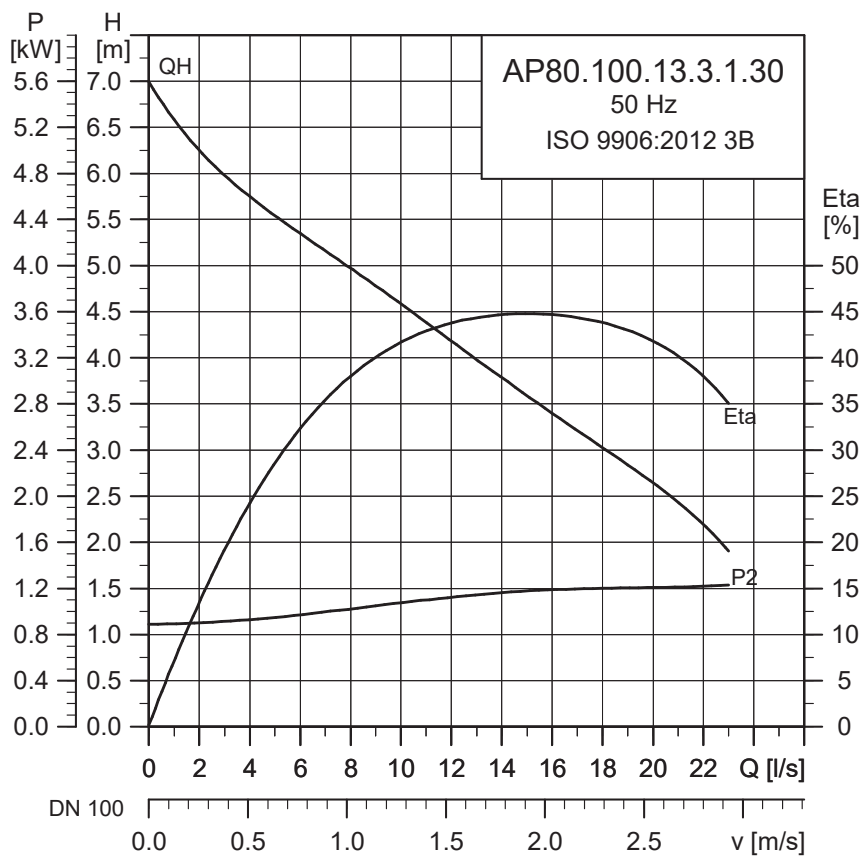

TM077235

Electrical data

Product number	Type	Voltage [V]	P1 [kW]	P2 [kW]	No of poles	Speed [rpm]	Starting method	I_N [A]	η_{motor} [%] at full load	$\cos \phi$
99895450	AP80.100.13.3.1.30	400	1.7	1.3	4	1450	DOL	3.3	0.77	0.77

Pump data

Impeller type	Max. solids size [mm]	Max. number of starts per hour	Max. installation depth [m]	Enclosure class	Insulation class	Max. liquid temperature [°C]	pH
1-channel	80 mm	15	20	IP68	H	40	6-11

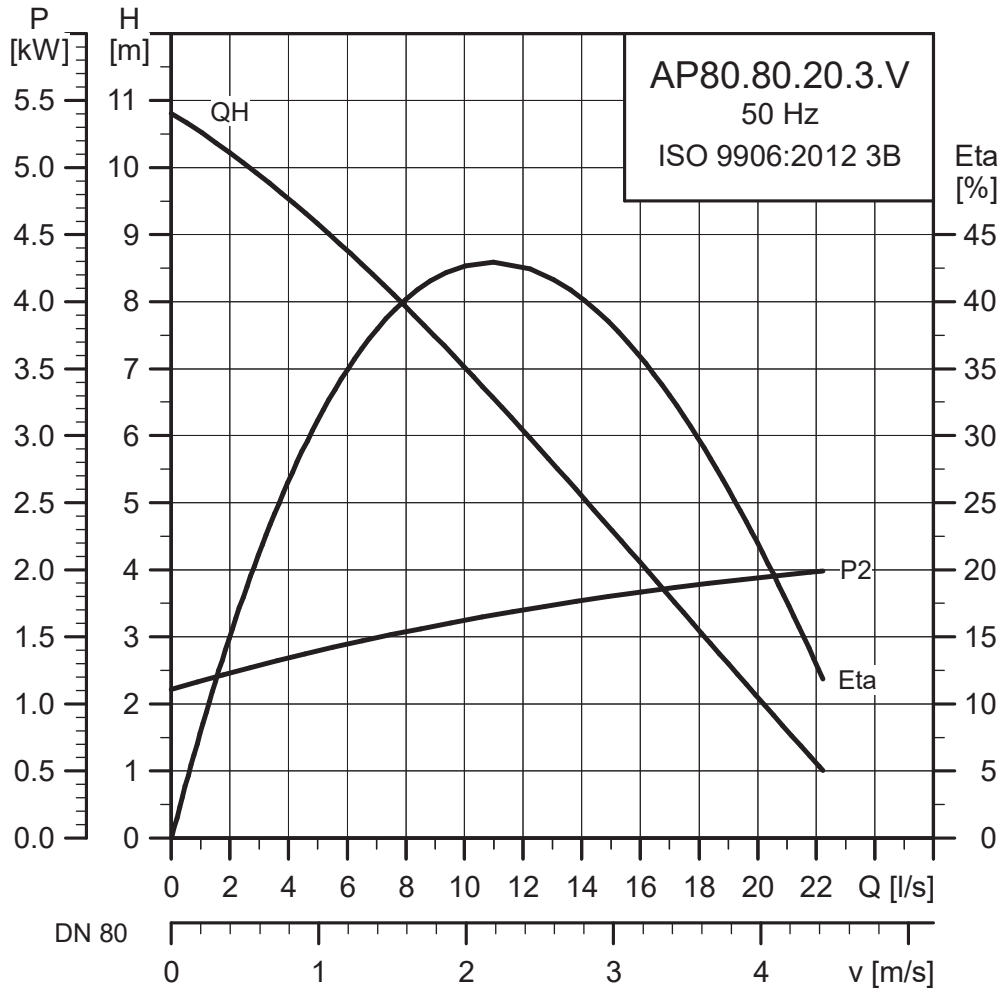

TM077232

Electrical data

Product number	Type	Voltage [V]	P1 [kW]	P2 [kW]	No of poles	Speed [rpm]	Starting method	I _N [A]	Cos φ
96005358	AP80.80.20.3.V	400	2.7	2.0	4	1450	DOL	5.2	0.76

Pump data

Impeller type	Max. solids size [mm]	Max. number of starts per hour	Max. installation depth [m]	Enclosure class	Insulation class	Max. liquid temperature [°C]	pH
Vortex	80 mm	15	20	IP68	H	40	6-11

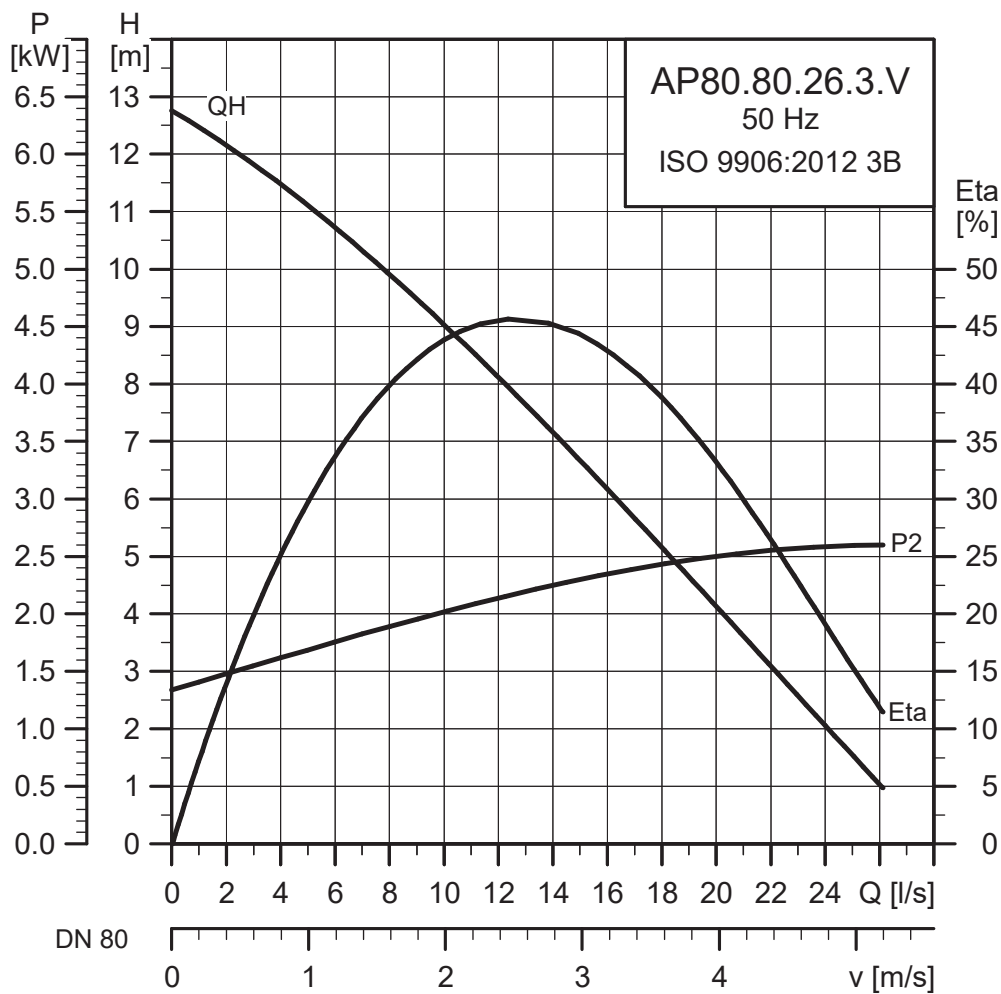

TM07233

Electrical data

Product number	Type	Voltage [V]	P1 [kW]	P2 [kW]	No of poles	Speed [rpm]	Starting method	I _N [A]	Cos φ
96005359	AP80.80.26.3.V	400	3.4	2.6	4	1450	DOL	6.2	0.80

Pump data

Impeller type	Max. solids size [mm]	Max. number of starts per hour	Max. installation depth [m]	Enclosure class	Insulation class	Max. liquid temperature [°C]	pH
Vortex	80 mm	15	20	IP68	H	40	6-11

10.7 AP100

Performance curve

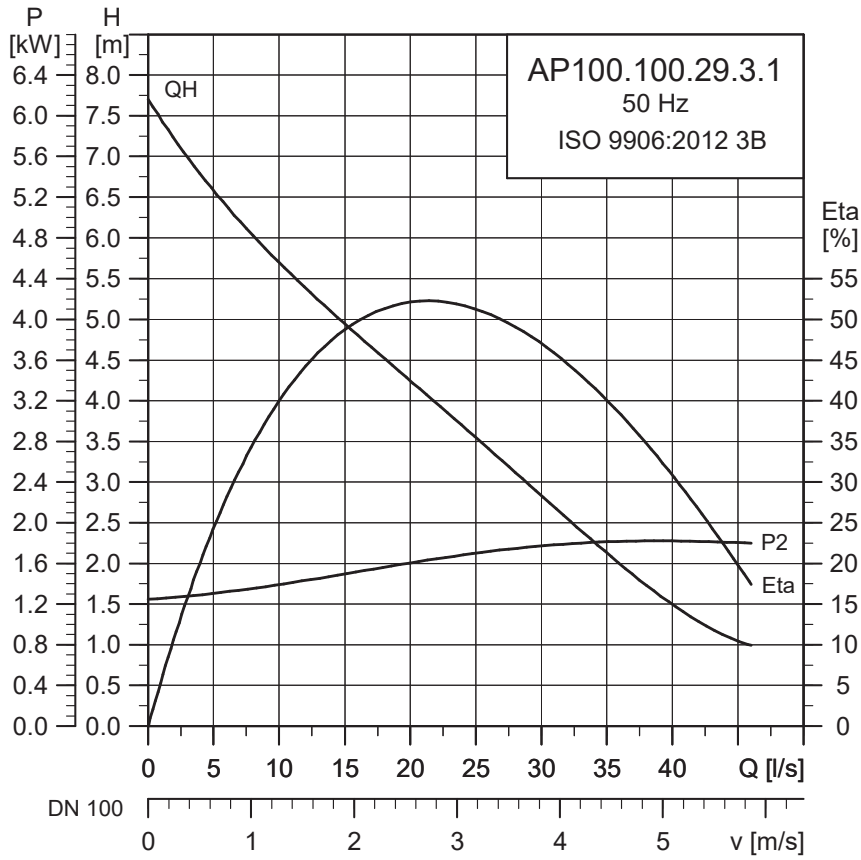

TM077236

Electrical data

Product number	Type	Voltage [V]	P1 [kW]	P2 [kW]	No of poles	Speed [rpm]	Starting method	I _N [A]	Cos φ
99895451	AP100.100.29.3.1	400	3.4	2.9	4	1450	DOL	5.8	0.87

Pump data

Impeller type	Max. solids size [mm]	Max. number of starts per hour	Max. installation depth [m]	Enclosure class	Insulation class	Max. liquid temperature [°C]	pH
1-channel	100 mm	15	20	IP68	H	40	6-11

11. Dimensions and weights

Auto-coupling dimensions

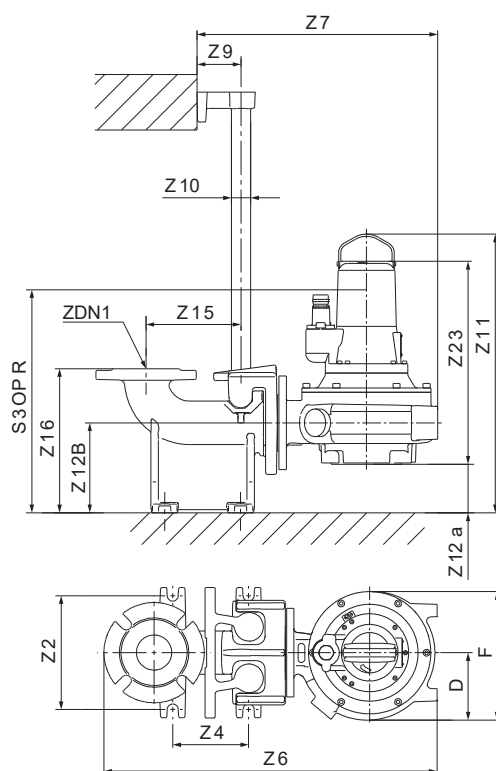

TM076971

	Power [kW]	D [mm]	F [mm]	Z2 [mm]	Z4 [mm]	Z6 [mm]	Z7 [mm]	Z9 [mm]	Z10 [mm]	Z11 [mm]	Z12a [mm]	Z12B [mm]	Z15 [mm]	Z16 [mm]	Z23 [mm]	ZDN1 [mm]	Weight [kg]
AP40	0.7	102	213	95	179	502	407	70	25.4	458	13	128	90	226	380	42	27
AP40.50	1.0	102	213	95	179	502	407	70	25.4	458	13	128	90	226	380	Rp2	30
AP50	1.0	110	232	210	140	664	478	81	38.1	583	65	166	175	266	468	50	40
	1.2	111	231	210	140	648	462	81	38.1	506	56	166	175	266	400	50	27
	1.8	110	232	210	140	664	478	81	38.1	583	65	166	175	266	468	50	42
AP50.50	1.5	88	176	95	179	443	348	70	25.4	439	37	128	90	226	352	Rp2	24
	1.5	88	176	95	179	443	348	70	25.4	439	37	128	90	226	352	Rp2	24
	1.5	88	176	95	179	443	348	70	25.4	439	37	128	90	226	352	Rp2	24
	1.5	88	176	95	179	443	348	70	25.4	439	37	128	90	226	352	Rp2	24
AP60	0.8	126	260	210	140	663	477	81	38.1	572	37	166	175	266	475	62	40
	1.8	126	260	210	140	663	477	81	38.1	609	37	166	175	266	512	62	45
AP70	0.9	159	355	220	160	755	563	81	38.1	603	107	200	171	345	496	80	40
	1.3	159	335	220	160	755	563	81	38.1	603	107	200	171	345	496	70	40
AP80.100	1.3	145	305	260	220	806	580	110	50.8	664	147	240	220	413	517	100	74
AP80.80	1.3	145	305	220	160	715	523	81	38.1	624	107	200	171	345	517	100	74
AP80.80	2.0	158	316	220	160	763	571	81	38.1	573	122	200	171	345	563	100	66
	2.6	158	316	220	160	763	571	81	38.1	573	122	200	171	345	563	100	66
AP100	2.9	147	323	260	220	711	485	110	50.8	852	117	240	220	413	737	100	104

Free-standing installation dimensions

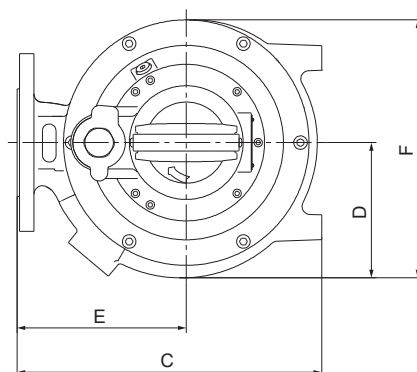
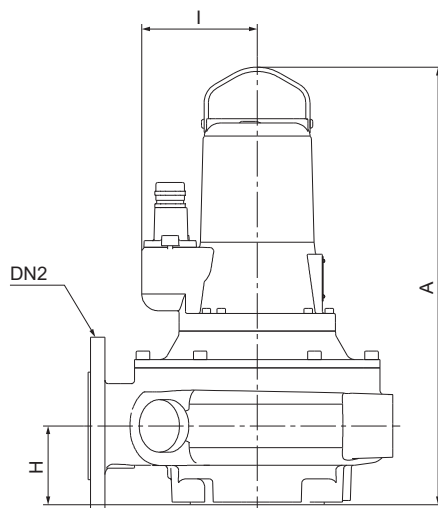

TM076975

	Power [kW]	A [mm]	C [mm]	D [mm]	E [mm]	F [mm]	H [mm]	DN2	Weight [kg]
AP40	0.7	445	262	102	160	213	115	R2	27
AP40.50.07.A.1.V	1.0	445	262	102	160	213.0	115	R2	30
	1.0	518	287	110	177	232	101	R2½	40
AP50	1.2	450	271	111	160	231	110	R2½	27
	1.8	518	287	110	177	232	101	R2½	42
AP50.50	1.5	402	203	88	115	176.0	91	R2	24
	1.5	402	203	88	115	176.0	91	R2	24
	1.5	402	203	88	115	176.0	91	R2	24
	1.5	402	203	88	115	176.0	91	R2	24
AP60	0.8	535	286	126	160	260	129	R2½	40
	1.8	572	286	126	160	260	129	R2½	45
AP70	0.9	586	400	159	240	355	183	DN80	40
	1.3	586	400	159	241	335	183	DN80	40
AP80	1.3	517	360	145	200	305	93	DN100 / DN80	74
	2.0	563	408	158	250	316	78	DN80	66
	2.6	563	408	158	250	316	78	DN80	66
AP100	2.9	737	265	147	265	323	123	DN100	104

13. Grundfos Product Center

Online search and sizing tool to help you make the right choice.
 From the international view, you can select your specific country to view the product range available to you.
 International view: <http://product-selection.grundfos.com>

All the information you need in one place

Performance curves, technical specifications, pictures, dimensional drawings, motor curves, wiring diagrams, spare parts, service kits, 3D drawings, documents, system parts. The Product Center displays any recent and saved items - including complete projects - right on the main page.

Downloads

On the product pages, you can download installation and operating instructions, data booklets, service instructions, etc., in PDF format.

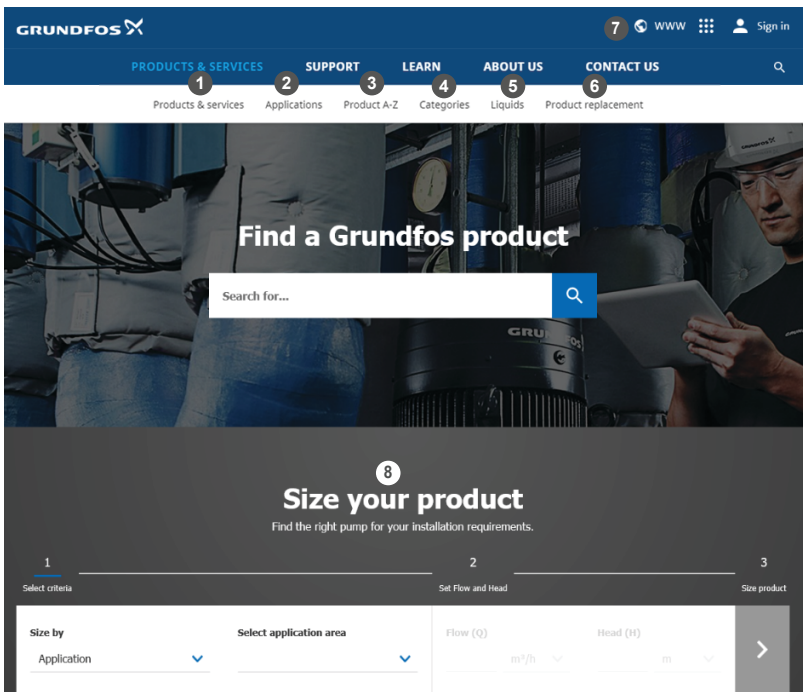
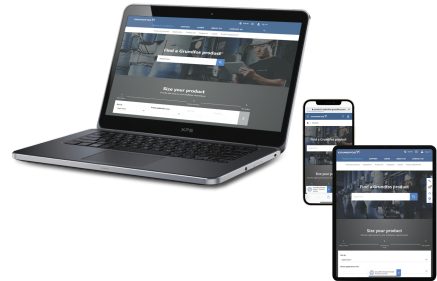

When you select your country, you will see the menus below. Note that some menus may not be available depending on the country.

Example: <https://product-selection.grundfos.com/uk>

Pos.	Description
1	Products & services enables you to find products and documents by typing a product number or name into the search field.
2	Applications enables you to choose an application to see how Grundfos can help you design and optimise your system.
3	Products A-Z enables you to look through a list of all the Grundfos products.
4	Categories enables you to look for a product category.
5	Liquids enables you to find pumps designed for aggressive, flammable or other special liquids.
6	Product replacement enables you to find a suitable replacement.
7	WWW enables you to select the country, which changes the language, the available product range and the structure of the website.
8	Sizing enables you to size a product based on your application and operating conditions.

